

ATTENZIONE - ATTENTION - ACHTUNG

- VERIFICARE LE MISURE DI INGOMBRO PER POSSIBILE INTERFERENZA SU ALCUNI MODELLI DI MACCHINE
- Please check the overall sizes for possible interferences on some machine models
- Bitte überprüfen sie das ausmass um mögliche interferenzen auf einigen maschinen modellen zu vermeiden

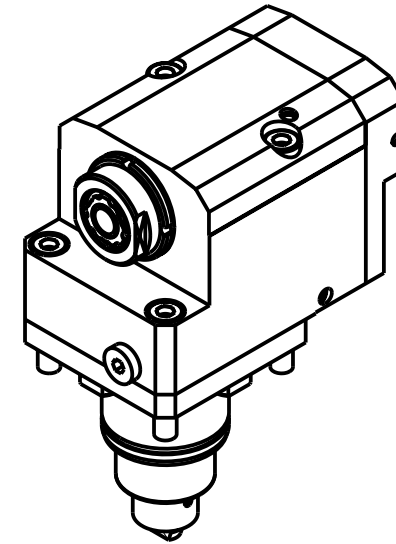
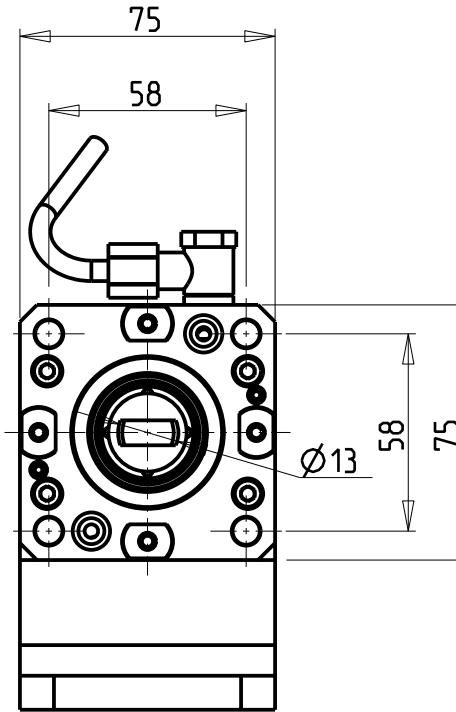
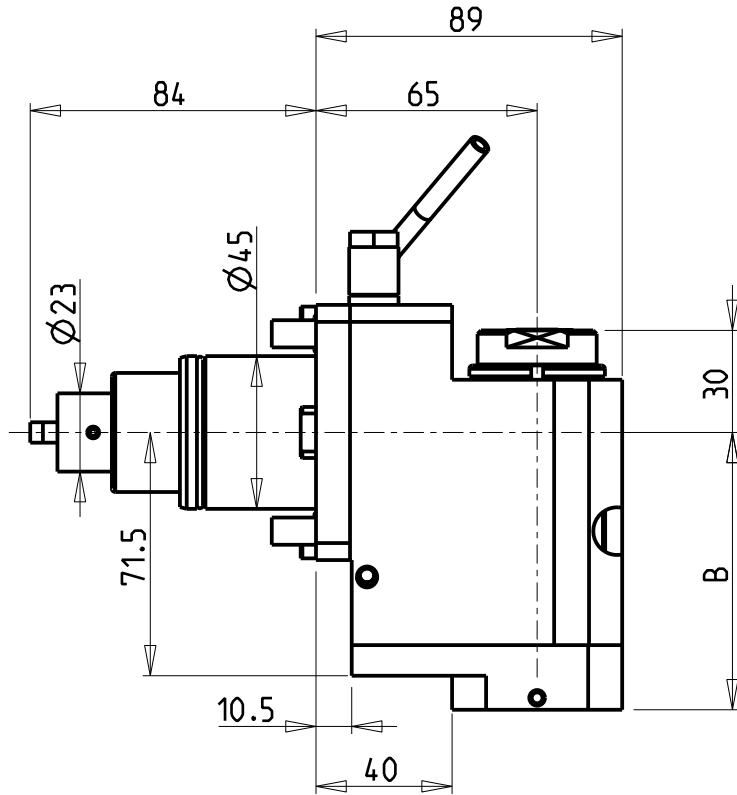

- Chiave inclusa
- Key included
- Schluessel inbegriffen

Cod. MT	Mandrino Spindle Spindel	I	RPM	Coppia Max Max Torque Max Drehmoment	Reversibile lato mandrino/contromandrino Reversible sub/main spindle side Umkehrbare Spindel-seite/ Gegenspindel-seite	Lubrificazione int. Coolant through Innenkuehlung	Lubrificazione est. Ext. coolant Aussenkuehlung	B	CHIAVI NON INCLUSE Keys not included Schluessel nicht einbegriffen		
									CHUB30	CHUB19_SP3	CHTAER16ZC
DW 02230316	ERA16	1:3	18000	10Nm	X	-	X	70.5	CHUB30	CHUB19_SP3	CHTAER16ZC
DW 02230416	ERA16	1:3	18000	10Nm	X	P=70bar	X	83	CHUB30	CHUB19_SP3	CHTAER16ZC

DN SOLUTIONS (DOOSAN) BMT 45

MOD: LYNX 220 M/LM/LMS/LY/LSY - LYNX 2100 M/LM/LMS/LY/LSY - LYNX 2105LY - PUMA MX1600 16ST. - PUMA TT1300SY/SYY

MODULO MOTORIZZATO ASSIALE ARRETRATO MOLTIPLICATO I=1:3 H=65mm

Axial gear-up I=1:3 rear-set driven tool H=65mm

Axial angetriebenes Werkzeug uebersetzt I=1:3 zurueckversetzt H=65mm

Subject to change without notice.

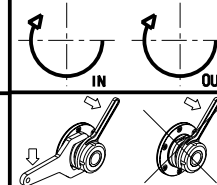

M.T. srl

Via Casino Albini 480
Tel. 0541/956034-957884
Fax 0541/956341
47842 S. GIOVANNI IN M. (RN)
e-mail: mtma@mtmarchetti.com
http://www.mtmarchetti.com



DW 0226-1-05