

ATTENZIONE - ATTENTION - ACHTUNG

- Per lo smontaggio degli utensili utilizzare sempre la chiave di contrasto come indicato nel manuale d'uso.
- For disassembly of the tools use always the contrast key as mentioned in the user instructions.
- Fuer das Abmontieren der Werkzeuge immer den Gegenschlüssel benutzen wie in der Bedienungsanleitung erwaeht.

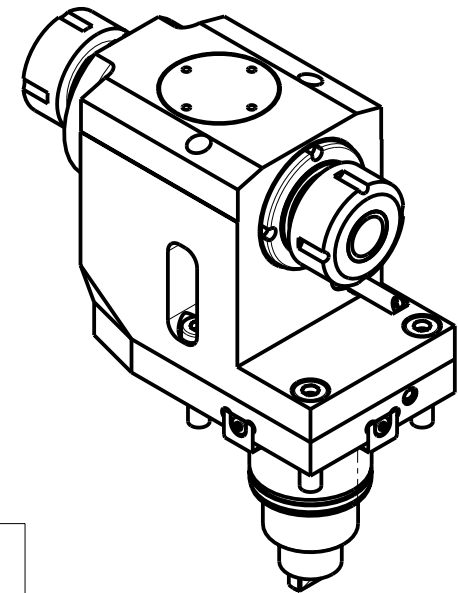

Cod. MT	Mandrino Spindle Spindel	I	RPM	Coppia Max Max Torque Max Drehmoment	Reversibile lato mandrino/contromandrino Reversible sub/main spindle side Umkehrbare Spindel-seite/Gegenspindel-seite	Lubrificazione est. Ext. coolant Aussenkuehlung	CHIAVI NON INCLUSE Keys not included Schlüssel nicht inbegriffen		
DW 01360125	ER25+ER25	1:1	6000	50Nm	X	X	CHSTER25	CHUB29	CHUB36

DN SOLUTIONS (DOOSAN) BMT 45
 MOD: LYNX 220 LMS/LSY - LYNX 2100 LMS/LSY - PUMA MX1600 16ST.

MODULO MOTORIZZATO ASSIALE ARRETRATO BISPORGENTE
 Axial opposite face rear-set driven tool
 Axial angetriebenes Werkzeug zurueckversetzt halb vorspringend

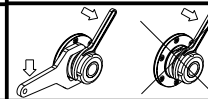

M.T. srl
 Via Casino Albini 480
 Tel. 0541/956034-957884
 Fax 0541/956341
 47842 S. GIOVANNI IN M. (RN)
 e-mail: mtma@mtmarchetti.com
 http://www.mtmarchetti.com



DW 0243-1-10

Subject to change without notice.

09/2024