

### ATTENZIONE - ATTENTION - ACHTUNG

- Su macchina PUMA TT1300 serie non arriva in centro mandrino.
- On machine PUMA TT1300 serie tool does not get to the centre of the spindle axis.
- Auf Maschinen PUMA TT1300 serie erreicht das Werkzeug nicht die Mitte der Werkzeug-Achse.

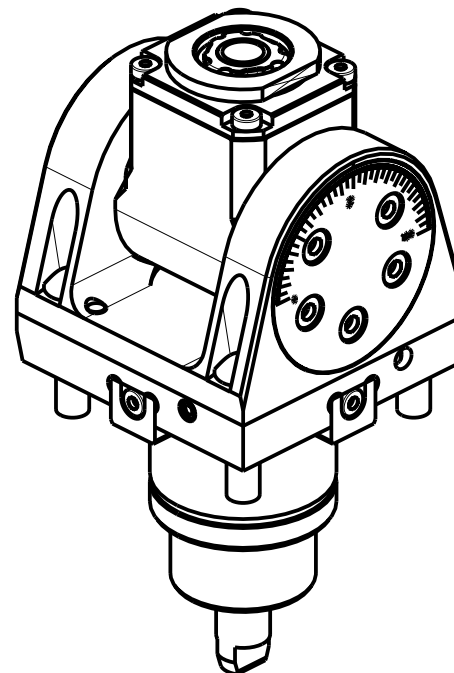

Cod. MT	Mandrino Spindle Spindel	I	RPM	Coppia Max Max Torque Max Drehmoment	Reversibile lato mandrino/contromandrino Reversible sub/main spindle side Umkehrbare Spindel-seite/ Gegenspindel-seite	Lubrificazione est. Ext. coolant Aussenkuehlung	CHIAVI INCLUSE Keys included Schlüssel inbegriffen			
DW00040116	ER A 16	1:1	6000	20Nm	X	X	CHUB19_SP3	CHUB32	CHESL05	CHTAER16ZC

DN SOLUTIONS (DOOSAN) BMT 45

MOD: LYNX 220 M/LM/LMS/LY/LSY - LYNX 2100 M/LM/LMS/LY/LSY - LYNX 2105LY - PUMA MX1600 16ST. - PUMA TT1300SY/SYY

MODULO MOTORIZZATO ORIENTABILE ±90°

±90° adjustable angle driven tool

Angetriebenes Werkzeug schwenkbar ±90°

Subject to change without notice.

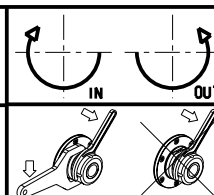

**M.T. srl**

Via Casino Albini 480  
Tel. 0541/956034-957884  
Fax 0541/956341  
47842 S. GIOVANNI IN M. (RN)  
e-mail: mtma@mtmarchetti.com  
http://www.mtmarchetti.com



DW 0335-1-00