

ATTENZIONE - ATTENTION - ACHTUNG

-Su macchine PUMA 280. PUMA TT1500-TT1800-TT2100 serie non arriva in centro mandrino.

-On machines PUMA 280. PUMA TT1500-TT1800-TT2100 series tool does not get to the centre of the spindle axis.

-Auf Maschinen PUMA 280. PUMA TT1500-TT1800-TT2100 serie erreicht das Werkzeug nicht die Mitte der Werkzeug-Achse.

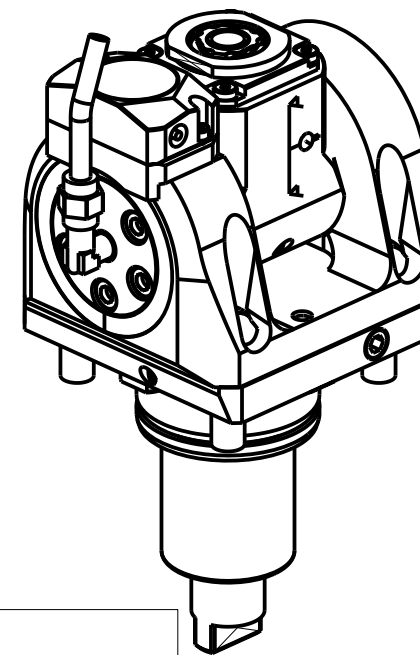

| Cod. MT | Mandrino Spindle Spindel | I | RPM | Coppia Max Max Torque Max Drehmoment | Reversibile lato mandrino/contromandrino Reversible sub/main spindle side Umkehrbare Spindelsete/Gegenspindelsete | Lubrificazione int. Coolant through Innenkuehlung | Lubrificazione est. Ext. coolant Aussenkuehlung | CHIAVI INCLUSE Keys included Schluessel inbegriffen | | | |
|------------|--------------------------|-----|-------|--------------------------------------|---|---|---|---|--------|------------|---------|
| | | | | | | | | CHUB19_SP3 | CHUB32 | CHTAER16ZC | CHESL07 |
| DW00665316 | ERA16 | 1:2 | 12000 | 8Nm | X | - | X | CHUB19_SP3 | CHUB32 | CHTAER16ZC | CHESL07 |
| DW00665416 | ERA16 | 1:2 | 12000 | 8Nm | X | P=70bar | X | CHUB19_SP3 | CHUB32 | CHTAER16ZC | CHESL07 |

DN SOLUTIONS (DOOSAN) BMT 55

MOD: PUMA 230-240M/MS-280LM - PUMA 1500-2000-2100-2500-2600M/MS/Y/SY - LINX 300 M - PUMA 2100-2600Y/SY 16ST. - PUMA H250TM - PUMA TW 2600 10ST. PUMA TT1500-1800-2100MS/SY/SYY - PUMA TL2000-2500 (M) - SMX2100ST - PUMA GT2100-2600 M - PUMA QL200HM - LYNX 2600 Y/SY 12ST. - PUMA DNT2100-2600M (BMT55)

MODULO MOTORIZZATO ORIENTABILE +/-90° MOLTIPLICATO I=1:2 CON NONIO DIGITALE H=47.5mm
 +/-90° adjustable angle driven tool geared-up I=1:2 with digital display H=47.5mm

Angetriebenes Werkzeug schwenkbar +/-90° uebersetzt I=1:2 mit digital display H=47.5mm

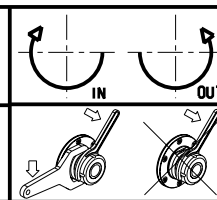

M.T. srl

Via Casino Albini 480
 Tel. 0541/956034-957884
 Fax 0541/956341
 47842 S. GIOVANNI IN M. (RN)
 e-mail: mtma@mtmarchetti.com
 http://www.mtmarchetti.com



DW 0336-2-01

Subject to change without notice.

09/2024