

ATTENZIONE - ATTENTION - ACHTUNG

- VERIFICARE LE MISURE DI INGOMBRO PER POSSIBILE INTERFERENZA SU ALCUNI MODELLI DI MACCHINE
- Please check the overall sizes for possible interferences on some machine models
- Bitte überprüfen sie das ausmass um mögliche interferenzen auf einigen maschinen modellen zu vermeiden

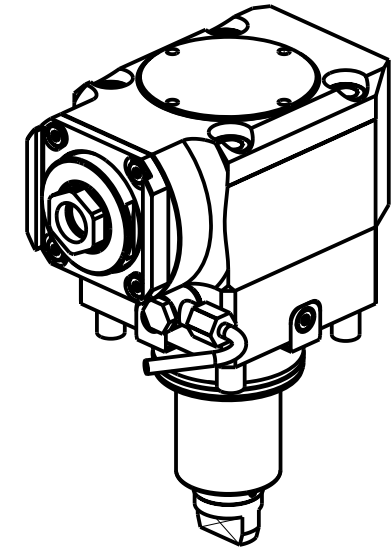
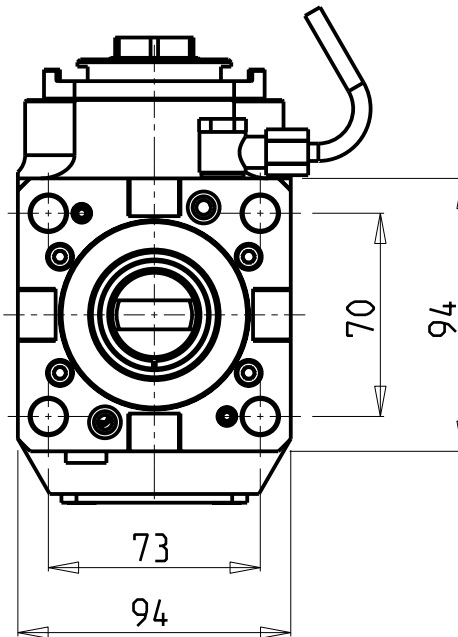
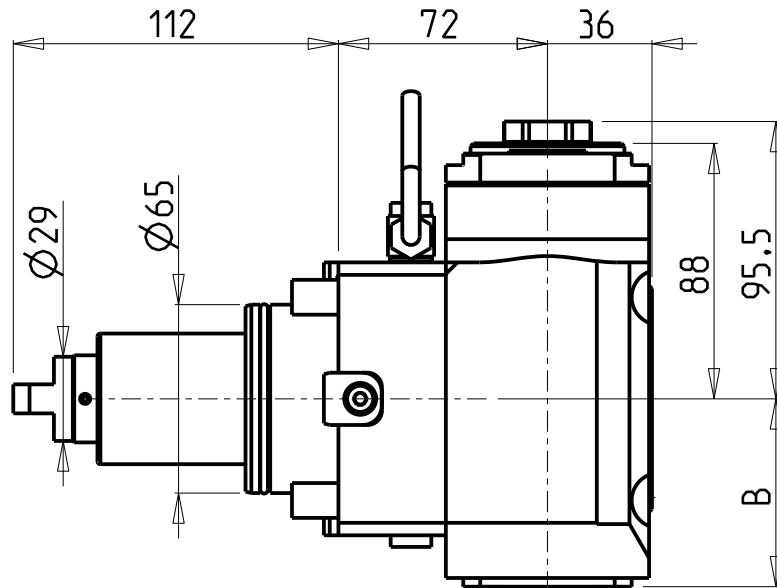

Cod. MT	Mandrino Spindle Spindel	I	RPM	Coppia Max Max Torque Max Drehmoment	Reversibile lato mandrino/contromandrino Reversible sub/main spindle side Umkehrbare Spindel-seite/ Gegenspindel-seite	Lubrificazione int. Coolant through Innenkuehlung	Lubrificazione est. Ext. coolant Aussenkuehlung	B	CHIAVI NON INCLUSE Keys not included Schlüssel nicht einbegriffen	
DW 03780125	ER A 25	1:2	12000	30Nm	X	-	X	64.7	OKU0650004 *	CHUB27
DW 03780225	ER A 25	1:2	12000	30Nm	X	P=70bar	X	73.2	OKU0650004 *	CHUB27

- Chiave inclusa
- Key included
- Schlüssel inbegriffen

DN SOLUTIONS (DOOSAN) BMT 65
 MOD: PUMA 300M/MS - V400M - PUMA 2100-2600M/MS/Y/SY (BMT65) - PUMA 3100 M/Y - VT 450M/TM
 PUMA INVERTURN 3000M - PUMA GT3100 M - PUMA DNT2100-2600M (BMT65)
MODULO MOTORIZZATO ASSIALE MOLTIPLICATO I=1:2 H=72mm
 Axial geared-up I=1:2 driven tool H=72mm
 Axial angetriebenes Werkzeug uebersetzt I=1:2 H=72mm

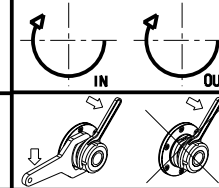

M.T. srl
 Via Casino Albini 480
 Tel. 0541/956034-957884
 Fax 0541/956341
 47842 S. GIOVANNI IN M. (RN)
 e-mail: mtma@mtmarchetti.com
 http://www.mtmarchetti.com



DW 0200-3-10

Subject to change without notice.

09/2024