

CUSCINETTI MAGGIORATI PER LAVORAZIONI PESANTI

Reinforced bearings for
heavy machining

Vergroesserte Lager fuer
schwerere Bearbeitungen

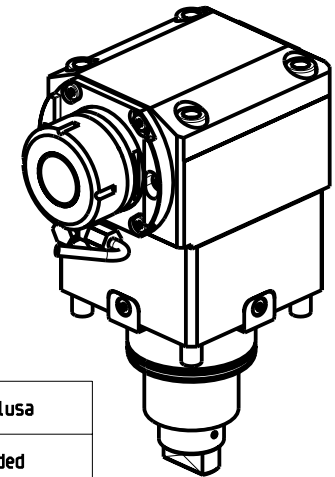

ATTENZIONE: Non si monta su macchina V8300M
WARNING: This tool can not be mounted on V8300M
ACHTUNG: Werkzeug darf nicht auf V8300M montiert werden

- Chiave inclusa
- Key included
- Schluessel inbegriffen

| Cod. MT | Mandrino Spindle Spindel | I | RPM | Coppia Max Max Torque Max Drehmoment | Reversibile lato mandrino/contromandrino Reversible sub/main spindle side Umkehrbare Spindel-seite/ Gegenspindel-seite | Lubrificazione int. Coolant through Innenkuehlung | Lubrificazione est. Ext. coolant Aussenkuehlung | A | A1 | A2 | B | D | L | CHIAVI NON INCLUDE Keys not included Schluessel nicht einbegriffen | |
|------------|--------------------------------|-----|------|--|---|---|---|-------|-------|----|------|----|----|--|--------------|
| DW01340140 | ER40 | 1:1 | 6000 | 140Nm | X | - | X | 109.7 | - | - | 64 | - | - | CHSTER40 | OKU0430007 • |
| DW01340240 | ER40 | 1:1 | 6000 | 140Nm | X | P=70bar | X | 109.7 | - | - | 76.5 | - | - | CHSTER40 | OKU0430007 • |
| DW01340725 | WELDON 25 | 1:1 | 6000 | 140Nm | X | - | X | - | 109.5 | - | 64 | - | - | - | - |
| DW01340825 | WELDON 25 | 1:1 | 6000 | 140Nm | X | P=70bar | X | - | 109.5 | - | 76.5 | - | - | - | - |
| DW01340522 | Ø22x19 | 1:1 | 6000 | 140Nm | X | - | X | - | - | 89 | 64 | 22 | 19 | CH_VTCROCE_M10 • | OKU0430007 • |

DN SOLUTIONS (DOOSAN) BMT 75

MOD: PUMA 400 - PUMA 480M/LM/XLM - PUMA 4100M - PUMA 5100M/Y - V550M - VT 750M/TM - V8300M

MODULO MOTORIZZATO ASSIALE MAGGIORATO H=110mm

Axial reinforced driven tool H=110mm

Axial angetriebenes Werkzeug vergroessert H=110mm

Subject to change without notice.

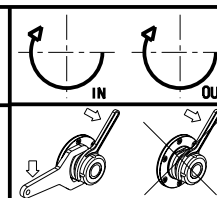

M.T. srl

Via Casino Albini 480
Tel. 0541/956034-957884
Fax 0541/956341
47842 S. GIOVANNI IN M. (RN)
e-mail: mtma@mtmarchetti.com
http://www.mtmarchetti.com



DW0170-4-30