

**ATTENZIONE - ATTENTION - ACHTUNG**

- Per lo smontaggio degli utensili utilizzare sempre la chiave di contrasto come indicato nel manuale d'uso.
- For disassembly of the tools use always the contrast key as mentioned in the user instructions.
- Fuer das Abmontieren der Werkzeuge immer den Gegenschlüssel benutzen wie in der Bedienungsanleitung erwaeht.

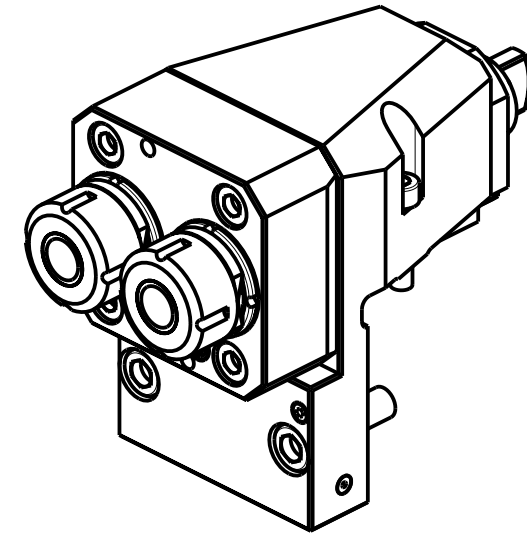
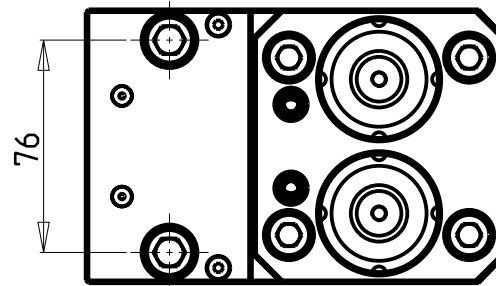
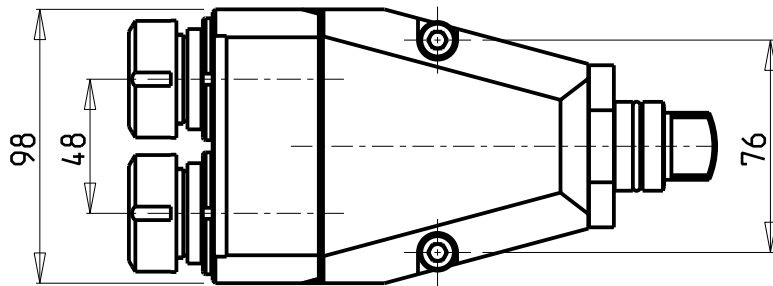
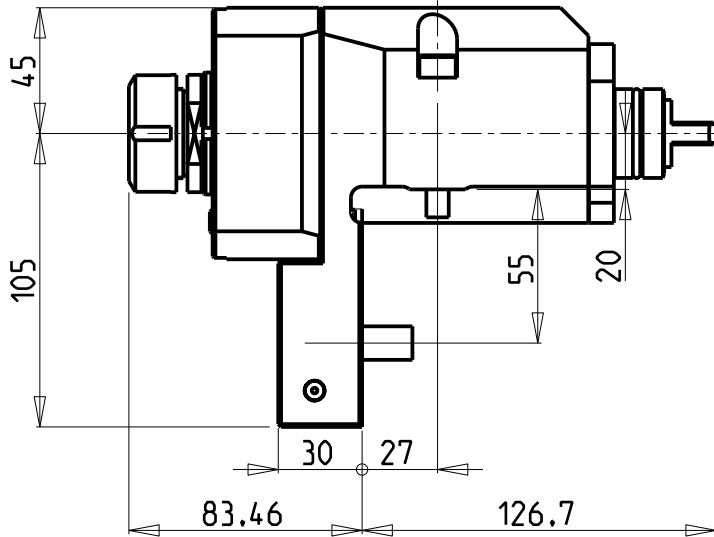

Cod. MT	Mandrino Spindle Spindel	I	RPM	Coppia Max Max Torque Max Drehmoment	Lubrificazione est. Ext. coolant Aussenkuehlung	CHIAVI NON INCLUSE Keys not included Schluesssel nicht einbegriffen	
MSL0470225	ER25	1:1	12000	30Nm	X	MNL0210007	CHSTER25

CMZ

MOD: TA15-20-25-30Y/MY/YS 12ST. - TC15-20-25-30-35Y/MY/YS 12ST./16ST. - TD15-20-25-30-35-45-55Y/MY/YS 12ST./16ST.

MODULO MOTORIZZATO RADIALE 2 USCITE IN Y 12000 RPM  
Radial single side twin head driven tool in Y 12000 rpm  
Radial angetriebenes Werkzeug 2 Ausgaenge in Y 12000 rpm

Subject to change without notice.

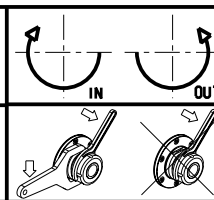

**M.T. srl**

Via Casino Albini 480  
Tel. 0541/956034-957884  
Fax 0541/956341  
47842 S. GIOVANNI IN M. (RN)  
e-mail: mtma@mtmarchetti.com  
http://www.mtmarchetti.com



CMZ080-2-01