

**ATTENZIONE - ATTENTION - ACHTUNG**

- VERIFICARE LE MISURE DI INGOMBRO PER POSSIBILE INTERFERENZA SU ALCUNI MODELLI DI MACCHINE
- Please check the overall sizes for possible interferences on some machine models
- Bitte überprüfen sie das ausmass um mögliche interferenzen auf einigen maschinen modellen zu vermeiden

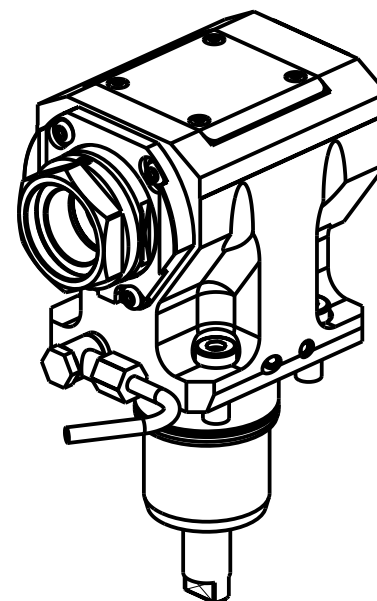

PER PORTAUTENSILI MODULARI MTSK-40 VEDI PAG. TBL300-1-40  
 FOR MTSK-40 QUICK CHANGE TOOLHOLDERS CLAMPINGS SEE PAGE TBL300-1-40  
 FUER MTSK-40 MODULARE WERKZEUGAUFNAHMEN SIEHE SEITE TBL300-1-40

- Chiave inclusa
- Key included
- Schlüssel inbegriffen

Cod. MT	Mandrino Spindel Spindel	I	RPM	Coppia Max Max Torque Max Drehmoment	Reversibile lato mandrino/contromandrino Reversible sub/main spindle side Umkehrbare Spindel-seite/ Gegenspindel-seite	Lubrificazione int. Coolant through Innenkuehlung	Lubrificazione est. Ext. coolant Aussenkuehlung	B	CHIAVI NON INCLUDE Keys not included Schluessel nicht einbegriffen	
NKM1410140	MTSK-40	1:1	6000	50Nm	X	-	X	56.5	CHUB46	OKU0650004 *
NKM1410240	MTSK-40	1:1	6000	50Nm	X	P=70bar	X	67.5	CHUB46	OKU0650004 *

**CMZ**  
 MOD: TX52 Y3/Y2 QUATTRO/Y2 TWIN - TX66 Y3/Y2 QUATTRO/Y2 TWIN - TTL 52 - TTL 66  
 TA15-20-25-30M/Y/MS/MY/YS 15 ST.

MODULO MOTORIZZATO ASSIALE MTSK H=75mm  
 Axial MTSK driven tool H=75mm  
 Axial MTSK angetriebenes Werkzeug H=75mm

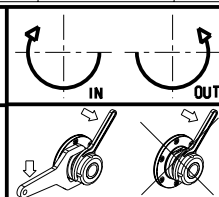

**M.T. srl**  
 Via Casino Albini 480  
 Tel. 0541/956034-957884  
 Fax 0541/956341  
 47842 S. GIOVANNI IN M. (RN)  
 e-mail: mtma@mtmarchetti.com  
 http://www.mtmarchetti.com



CMZ150-3-21-K

Subject to change without notice.

09/2024