

CUSCINETTI MAGGIORATI PER LAVORAZIONI PESANTI

Reinforced bearings for
heavy machining

Vergroesserte Lager fuer
schwerere Bearbeitungen

ATTENZIONE - ATTENTION - ACHTUNG

- Per lo smontaggio degli utensili utilizzare sempre la chiave di contrasto come indicato nel manuale d'uso.
- For disassembly of the tools use always the contrast key as mentioned in the user instructions.
- Fuer das Abmontieren der Werkzeuge immer den Gegenschlüssel benutzen wie in der Bedienungsanleitung erwaeht.

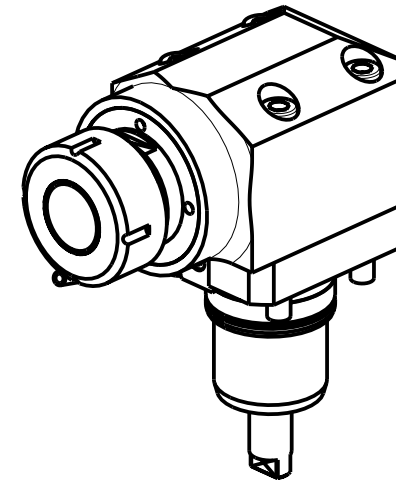

- Chiave inclusa
- Key included
- Schluessel inbegriffen

Cod. MT	Mandrino Spindle Spindel	I	RPM	Coppia Max Max Torque Max Drehmoment	Reversibile lato mandrino/contromandrino Reversible sub/main spindle side Umkehrbare Spindel-seite/ Gegenspindel-seite	Lubr.interna Coolant through Innenkuehlung	Lubrificazione est. Ext. coolant Aussenkuehlung	A	B	A1	ØD	L	CHIAVI NON INCLUDE Keys not included Schluessel nicht einbegriffen	
NKM0070140	ER40	1:1	6000	50Nm	X	-	X	119.16	48	-	-	-	CHUB46	CHSTER40
NKM0070240	ER40	1:1	6000	50Nm	X	P=70bar	X	119.16	58	-	-	-	CHUB46	CHSTER40
NKM0072519	Ø1"x19	1:1	6000	50Nm	X	-	X	-	48	91.5	1"	19	CHUB46	CH_VTCROCE_M12 ▪
NKM0072721	Ø27x21	1:1	6000	50Nm	X	-	X	-	48	91.5	27	20	CHUB36	CH_VTCROCE_M12 ▪

CMZ

MOD: TX52 Y3/Y2 QUATTRO/Y2 TWIN - TX66 Y3/Y2 QUATTRO/Y2 TWIN - TTL 52 - TTL 66
TA15-20-25-30M/Y/MS/MY/YS 15 ST.

MODULO MOTORIZZATO ASSIALE MAGGIORATO H=55mm

Axial reinforced driven tool H=55mm

Axial angetriebenes Werkzeug vergroessert H=55mm

Subject to change without notice.

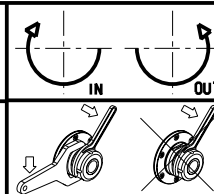

M.T. srl

Via Casino Albini 480
Tel. 0541/956034-957884
Fax 0541/956341
47842 S. GIOVANNI IN M. (RN)
e-mail: mtma@mtmarchetti.com
http://www.mtmarchetti.com



CMZ170-3-10