

**CUSCINETTI MAGGIORATI
PER LAVORAZIONI PESANTI**

Reinforced bearings for heavy machining

Vergroesserte Lager fuer schwerere Bearbeitungen

ATTENZIONE - ATTENTION - ACHTUNG

- Per lo smontaggio degli utensili utilizzare sempre la chiave di contrasto come indicato nel manuale d'uso.
- For disassembly of the tools use always the contrast key as mentioned in the user instructions.
- Fuer das Abmontieren der Werkzeuge immer den Gegenschlüssel benutzen wie in der Bedienungsanleitung erwaeht.

ATTENZIONE - ATTENTION - ACHTUNG

- VERIFICARE LE MISURE DI INGOMBRO PER POSSIBILE INTERFERENZA SU ALCUNI MODELLI DI MACCHINE
- Please check the overall sizes for possible interferences on some machine models
- Bitte ueberpruefen sie das ausmass um moegliche interferenzen auf einigen maschinen modellen zu vermeiden

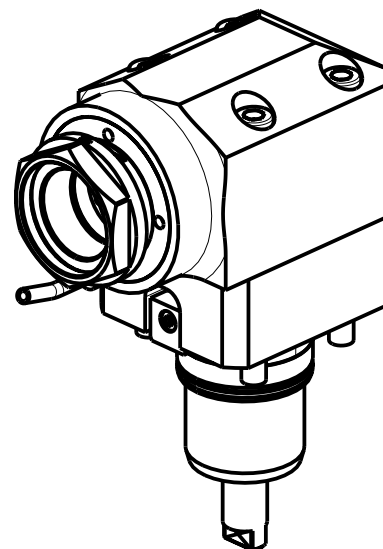

PER PORTAUTENSILI MODULARI MTSK-50 VEDI PAG. TBL300-1-50
FOR MTSK-50 QUIK CHANGE TOOLHOLDERS CLAMPINGS SEE PAGE TBL300-1-50
FUER MTSK-50 MODULARE WERKZEUGAUFNAHMEN SIEHE SEITE TBL300-1-50

Cod. MT	Mandrino Spindle Spindel	I	RPM	Coppia Max Max Torque Max Drehmoment	Reversibile lato mandrino/contromandrino Reversible sub/main spindle side Umkehrbare Spindel-seite/ Gegenspindel-seite	Lubr.interna Coolant through Innenkuehlung	Lubrificazione est. Ext. coolant Aussenkuehlung	B	CHIAVI NON INCLUSE Keys not included Schluessel nicht einbegriffen	
NKM1010150	MTSK-50	1:1	6000	50Nm	X	-	X	48	CHUB46	CHUB55
NKM1010250	MTSK-50	1:1	6000	50Nm	X	P=70bar	X	58	CHUB46	CHUB55

CMZ

MOD: TX52 Y3/Y2 QUATTRO/Y2 TWIN - TX66 Y3/Y2 QUATTRO/Y2 TWIN - TTL 52 - TTL 66

MODULO MOTORIZZATO ASSIALE MAGGIORATO MTSK H=75mm

Axial MTSK reinforced driven tool H=75mm

Axial MTSK angetriebenes Werkzeug vergroessert H=75mm

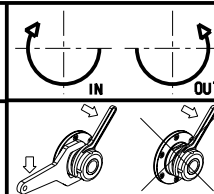

M.T. srl

Via Casino Albini 480
Tel. 0541/956034-957884
Fax 0541/956341

47842 S. GIOVANNI IN M. (RN)
e-mail: mtma@mtmarchetti.com
http://www.mtmarchetti.com



CMZ170-3-20-K

Subject to change without notice.

09/2024