

ATTENZIONE - ATTENTION - ACHTUNG

- Per lo smontaggio degli utensili utilizzare sempre la chiave di contrasto come indicato nel manuale d'uso.
- For disassembly of the tools use always the contrast key as mentioned in the user instructions.
- Fuer das Abmontieren der Werkzeuge immer den Gegenschlüssel benutzen wie in der Bedienungsanleitung erwaeht.

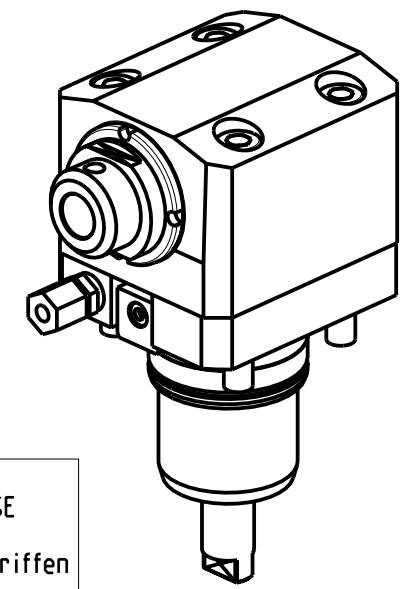

Cod. MT	Mandrino Spindle Spindel	I	RPM	Coppia Max Max Torque Max Drehmoment	Reversibile lato mandrino/contromandrino Reversible sub/main spindle side Umkehrbare Spindelsete/Gegenspindelsete	Lubrificazione est. Ext. coolant Aussenkuehlung	A	A1	D	D1	CHIAVI NON INCLUSE Keys not included Schluesel nicht einbegriffen	
NKM0039125	ER25	1:1	6000	50Nm	X	X	-	80.44	-	-	CHUB36	CHSTER25
NKM0039108	WELDON 8	1:1	6000	50Nm	X	X	76.5	-	8	29	-	-
NKM0039110	WELDON 10	1:1	6000	50Nm	X	X	76.5	-	10	29	-	-
NKM0039112	WELDON 12	1:1	6000	50Nm	X	X	76.5	-	12	29	-	-
NKM0039116	WELDON 16	1:1	6000	50Nm	X	X	73.7	-	16	32	-	-

CMZ
 MOD: TX52 Y3/Y2 QUATTRO/Y2 TW IN - TX66 Y3/Y2 QUATTRO/Y2 TW IN - TTL 52 - TTL 66
 TA15-20-25-30M/Y/MS/MY/YS 15 ST.

MODULO MOTORIZZATO ASSIALE PER POLIGONATURA INTERNA H=55mm
 Axial driven tool for internal polygon-making H=55mm
 Axial angetriebenes Werkzeug fuer interne Facettierung H=55mm

Subject to change without notice.

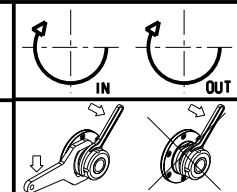

M.T. srl
 Via Casino Albini 480
 Tel. 0541/956034-957884
 Fax 0541/956341
 47842 S. GIOVANNI IN M. (RN)
 e-mail: mtma@mtmarchetti.com
 http://www.mtmarchetti.com



CMZ230-3-10