

### ATTENZIONE - ATTENTION - ACHTUNG

- Per lo smontaggio degli utensili utilizzare sempre la chiave di contrasto come indicato nel manuale d'uso.
- For disassembly of the tools use always the contrast key as mentioned in the user instructions.
- Fuer das Abmontieren der Werkzeuge immer den Gegenschlüssel benutzen wie in der Bedienungsanleitung erwäehnt.

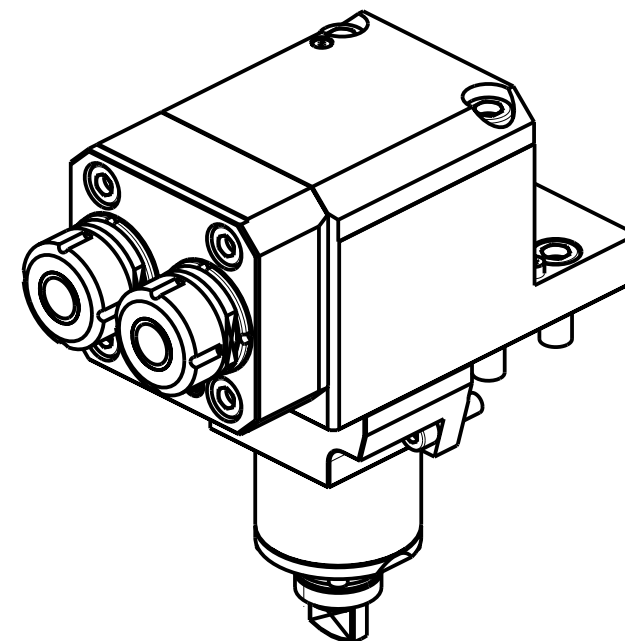

Cod. MT	Mandrino Spindle Spindel	I	RPM	Coppia Max Max Torque Max Drehmoment	Lubrificazione est. Ext. coolant Aussekkuehlung	A	CHIAVI NON INCLUSE Keys not included Schlüssel nicht einbegriffen	
MSL0180216	ER16	1:1	6000	30Nm	X	120	CHUB17	CHMNER16
MSL0180225	ER25	1:1	6000	30Nm	X	121	MNL0210007	CHSTER25

CMZ

MOD: TA15-20-25-30Y/MY/YS 12ST. - TC15-20-25-30-35Y/MY/YS 12ST./16ST. - TD15-20-25-30-35-45-55Y/MY/YS 12ST./16ST.

MODULO MOTORIZZATO ASSIALE 2 USCITE IN Y  
Axial single side twin head driven tool in Y  
Axial angetriebenes Werkzeug 2 Ausgaenge in Y

Subject to change without notice.

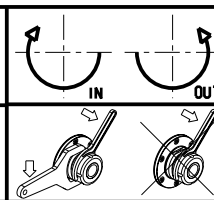

**M.T. srl**

Via Casino Albini 480  
Tel. 0541/956034-957884  
Fax 0541/956341  
47842 S. GIOVANNI IN M. (RN)  
e-mail: mtma@mtmarchetti.com  
<http://www.mtmarchetti.com>



CMZ260-2-10

09/2024