

**ATTENZIONE - ATTENTION - ACHTUNG**

- VERIFICARE LE MISURE DI INGOMBRO PER POSSIBILE INTERFERENZA SU ALCUNI MODELLI DI MACCHINE
- Please check the overall sizes for possible interferences on some machine models
- Bitte überprüfen sie das ausmass um mögliche interferenzen auf einigen maschinen modellen zu vermeiden

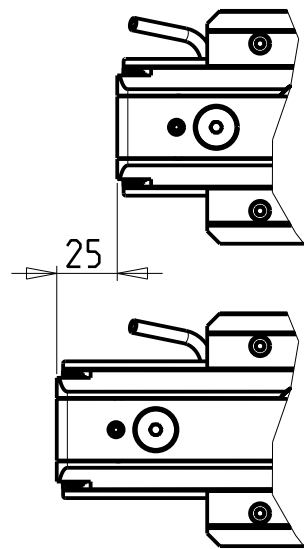
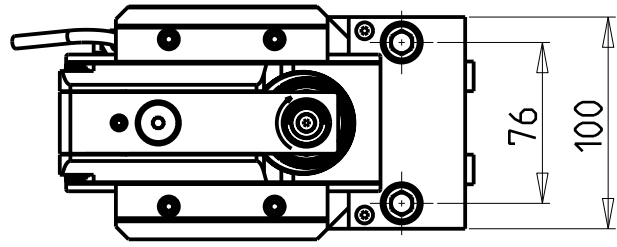

**DOTAZIONI - SUPPLIED WITH - AUSSTATTUNG**

N°1 Boccola di riduz.  $\varnothing 16-\varnothing 12$  e N°1 Boccola di riduz.  $\varnothing 16-\varnothing 10$   
 N°1 Reduction bush  $\varnothing 16-\varnothing 12$  and N°1 Reduction bush  $\varnothing 16-\varnothing 10$   
 N°1 Reduzierbuchsen  $\varnothing 16-\varnothing 12$  und N°1 Reduzierbuchsen  $\varnothing 16-\varnothing 10$

PER UTENSILI STOZZATORI VEDI PAG. TBL400-1-00  
 FOR DRIVEN SLOTTING TOOL CUTTING-TOOLS SEE PAGE TBL400-1-00  
 FÜR NUTENSTOSS-WERKZEUG SCHNEIDWERKZEUGE SIEHE SEITE TBL400-1-00

Cod. MT	I	RPM MAX	Lubr. esterna Ext. coolant Aussenkuehlung
MSL0460200	4:1	2400	X

**CMZ**  
 MOD: TL25AM/AMS/BM/BMS - TL20M/MS/TM - TA15-20-25-30M/Y/MS/MY/YS - TC15-20-25-30-35M/Y/MS/MY/YS  
 TD15-20-25-30-35-45-55M/Y/MS/MY/YS  
 MODULO MOTORIZZATO STOZZATORE CORSA 25mm H=80mm  
 Slotting driven tool 25mm stroke H=80mm  
 Keilnutenstossmaschine 25mm Hub H=80mm

**M.T. srl**  
 Via Casino Albini 480  
 Tel. 0541/956034-957884  
 Fax 0541/956341  
 47842 S. GIOVANNI IN M. (RN)  
 e-mail: mtma@tmarchetti.com  
 http://www.tmmarchetti.com

Subject to change without notice.