

-COMPATIBILE CON UTENSILI COMMERCIALI AD INSERTI
 -COMPATIBLE WITH COMMERCIAL INSERT CUTTING-TOOLS
 -KOMPATIBEL MIT HANDELSÜBLICHEN SCHNEIDWERKZEUGEN

ATTENZIONE - ATTENTION - ACHTUNG

- VERIFICARE LE MISURE DI INGOMBRO PER POSSIBILE INTERFERENZA SU ALCUNI MODELLI DI MACCHINE
- Please check the overall sizes for possible interferences on some machine models
- Bitte überprüfen sie das ausmass um mögliche interenzen auf einigen maschinen modellen zu vermeiden

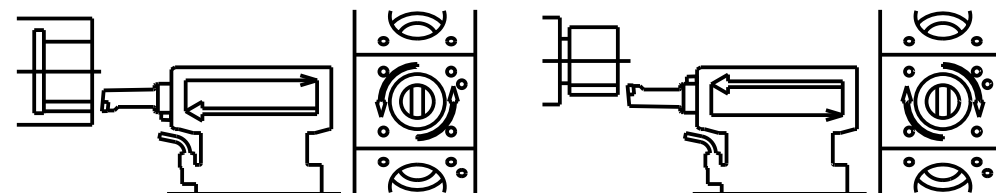
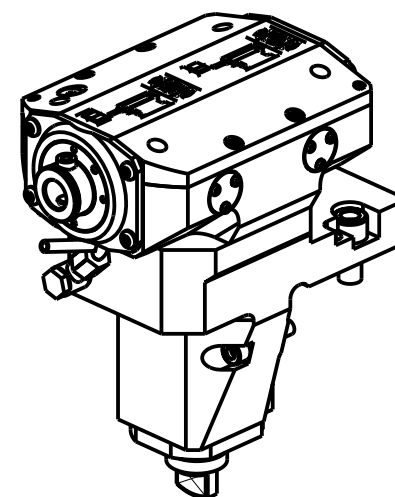

Cod. MT	I	RPM MAX	Lubr. esterna Ext. coolant Aussenkuehlung
MSL0670100	1:1	500	X

CMZ

MOD:TL25AM/AMS/BM/BMS - TL20M/MS/TM - TA15-20-25-30M/Y/MS/MY/YS 12ST. - TC15-20-25-30-35M/Y/MS/MY/YS 12ST./16ST.
 TD15-20-25-30-35-45-55M/Y/MS/MY/YS 12ST./16ST.

MODULO MOTORIZZATO BROCCIAITORE CORSA 50mm H=85mm
 Driven Broaching Toolholder 50mm stroke H=85mm
 Angetriebenes Nutzenstoßwerkzeug 50mm Hub H=85mm

M.T. srl

Via Casino Albini 480
 Tel. 0541/956034-957884
 Fax 0541/956341
 47842 S. GIOVANNI IN M. (RN)
 e-mail: mtma@mtmarchetti.com
 http://www.mtmarchetti.com



CMZ360-2-50

Subject to change without notice.

09/2024