

### ATTENZIONE - ATTENTION - ACHTUNG

- VERIFICARE LE MISURE DI INGOMBRO PER POSSIBILE INTERFERENZA SU ALCUNI MODELLI DI MACCHINE
- Please check the overall sizes for possible interferences on some machine models
- Bitte überprüfen sie das ausmass um mögliche interferenzen auf einigen maschinen modellen zu vermeiden

### ATTENZIONE - ATTENTION - ACHTUNG

- Per lo smontaggio degli utensili utilizzare sempre la chiave di contrasto come indicato nel manuale d'uso.
- For disassembly of the tools use always the contrast key as mentioned in the user instructions.
- Fuer das Abmontieren der Werkzeuge immer den Gegenschlüssel benutzen wie in der Bedienungsanleitung erwaeht.

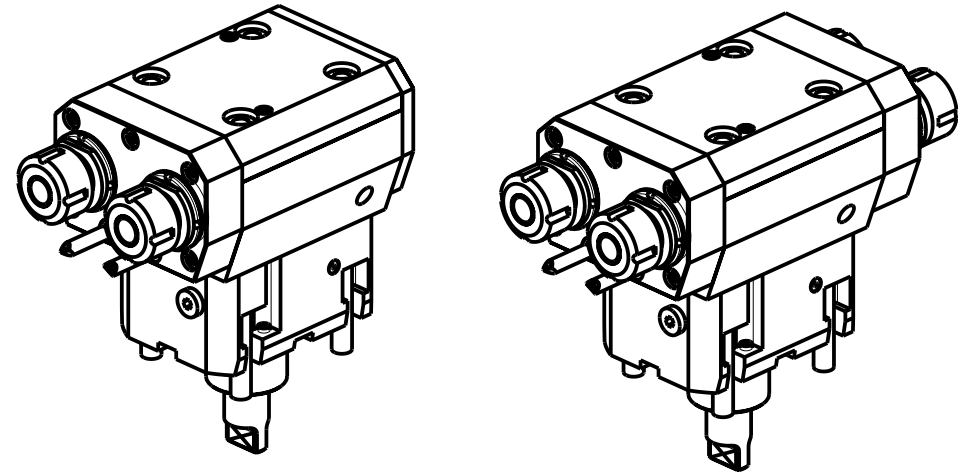
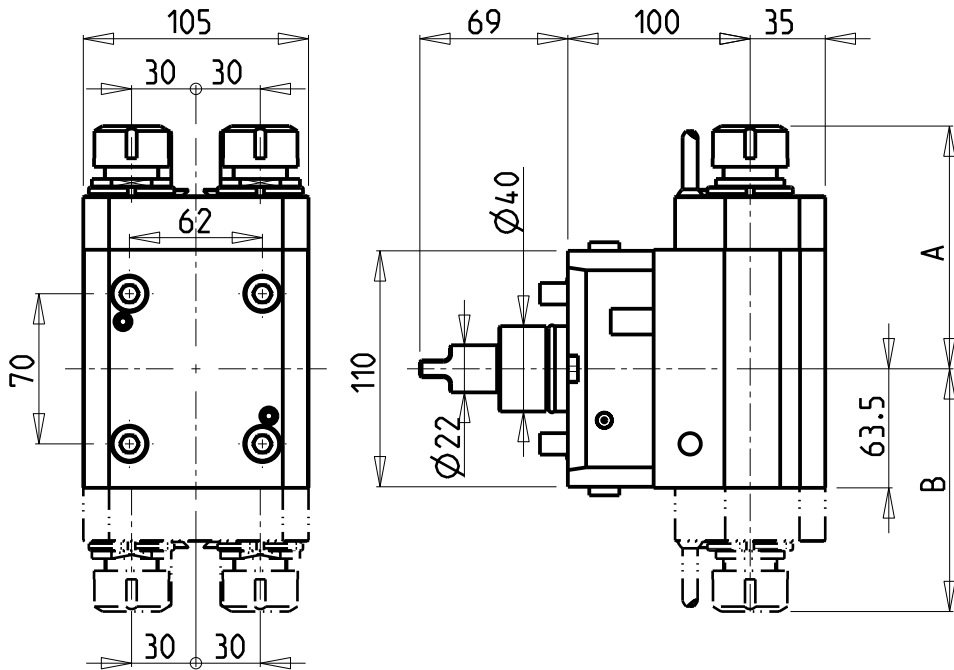

Cod. MT	Mandrino Spindle Spindel	I	RPM	Coppia Max Max Torque Max Drehmoment	N°Utensili N°Tools N°Werkzeuge	Reversibile lato mandrino/contromandrino Reversible sub/main spindle side Umkehrbare Spindel-seite/ Gegenspindel-seite	Lubr.esterna Ext. coolant Aussenkuehlung	A	B	CHIAVI NON INCLUSE Keys not included Schluessel nicht einbegriffen	
MNZ0041316	ERA16	1:1	6000	40Nm	2	X	X	96.63	-	CHUB32	CHUB19_SP3
MNZ0041320	ER20	1:1	6000	40Nm	2	X	X	113.16	-	CHUB32	CHSTER20
MNZ0041416	ERA16+ERA16	1:1	6000	40Nm	2+2	X	X	96.63	96.63	CHUB32	CHUB19_SP3
MNZ0041420	ER20+ER20	1:1	6000	40Nm	2+2	X	X	113.16	113.16	CHUB32	CHSTER20

### DMG-MORI

NZ1500/2000 - NZX1500/2000 - NT3100/3150/3200 - NL1500/2000/2500 20 STAZ. - NLX1500/2000/2500 20 STAZ.  
 NT1000/2000 - DURATURN 2050MC/2550MC - ALC/ALX1500/2000/2500 (BMT40)

MODULO MOTORIZZATO ASSIALE 2/4 USCITE IN Y H=100mm

Axial multiple 2/4 outlet driven tool in Y H=100mm

Axial angetriebenes Mehrspindel-Werkzeug 2/4 Ausgaenge in Y H=100mm

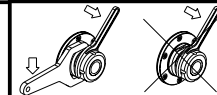

### M.T. srl

Via Casino Albini 480  
 Tel. 0541/956034-957884  
 Fax 0541/956341  
 47842 S. GIOVANNI IN M. (RN)  
 e-mail: mtma@mtmarchetti.com  
 http://www.mtmarchetti.com



MNZ268-1-10

Subject to change without notice.

09/2024