

MNZ0092060

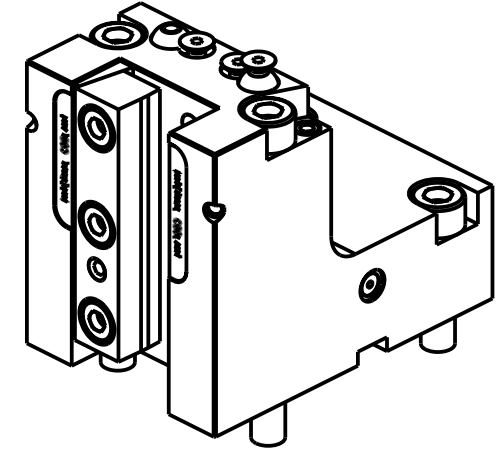
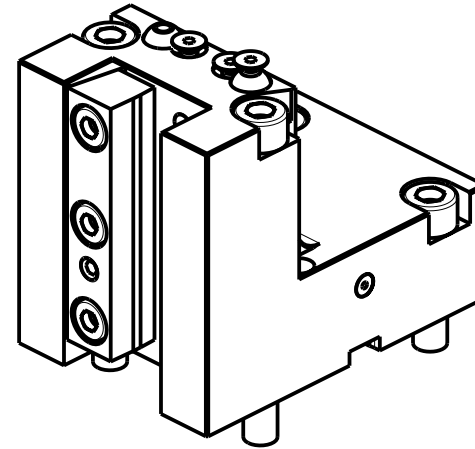
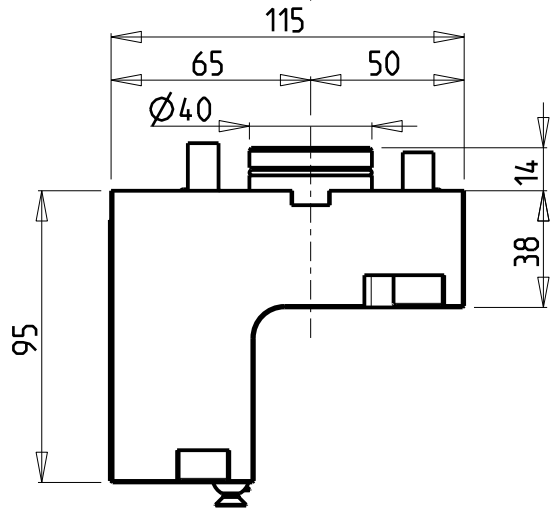

Cod. MT	N°Utensili N°Tools N°Werkzeuge	Reversibile lato mandrino/contromandrino Reversible sub/main spindle side Umkehrbare Spindel-seite/ Gegenspindel-seite	Lubrificazione int. Coolant through Innenkuehlung	Lubrificazione est. Ext. coolant Aussenkuehlung	Misure Dimensions Masse	B	H
MNZ0092010	1	X	-	X	mm	20	20
MNZ0092060	1	X	P=70bar	X	mm	20	20
MNZ0091915	1	X	-	X	Inch	3/4"	3/4"

DMG-MORI

NZ-NZX1500/2000 - NZX2500 (BMT40) - NT3100/3150/3200 - NL1500/2000/2500 20 STAZ. - NLX1500/2000/2500 20 STAZ. - NT1000/2000 - NTX500 (BMT40) - NTX1000/2000
NTX1000/2000/2500/3000 2ND GEN. 12ST. - DURATURN 2050MC/2550MC - NRX2000 - ALC/ALX1500/2000/2500 (BMT40) - ECOTURN 450 (BMT40) - NZ DUE/TRE/QUATTRO (BMT40)

PORTAUTENSILE RADIALE SINGOLO QD=20mm / QD=3/4" H=95mm

Radial single static tool QD=20mm / QD=3/4" H=95mm

Radial Single-Werkzeughalter QD=20mm / QD=3/4" H=95mm

M.T. srl

Via Casino Albini 480
Tel. 0541/956034-957884

Fax 0541/956341

47842 S. GIOVANNI IN M. (RN)

e-mail: mtma@tmarchetti.com

http://www.tmmarchetti.com



MNZ420-1-10