

ATTENZIONE - ATTENTION - ACHTUNG

- VERIFICARE LE MISURE DI INGOMBRO PER POSSIBILE INTERFERENZA SU ALCUNI MODELLI DI MACCHINE
- Please check the overall sizes for possible interferences on some machine models
- Bitte überprüfen sie das ausmass um mögliche interferenzen auf einigen maschinen modellen zu vermeiden

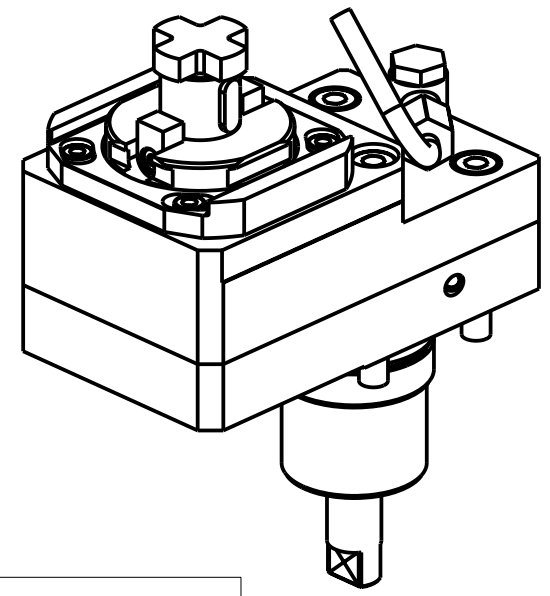
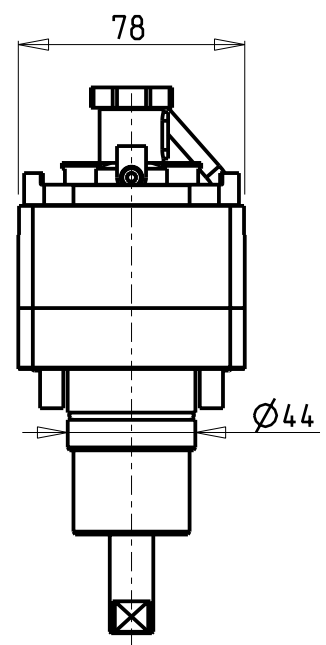
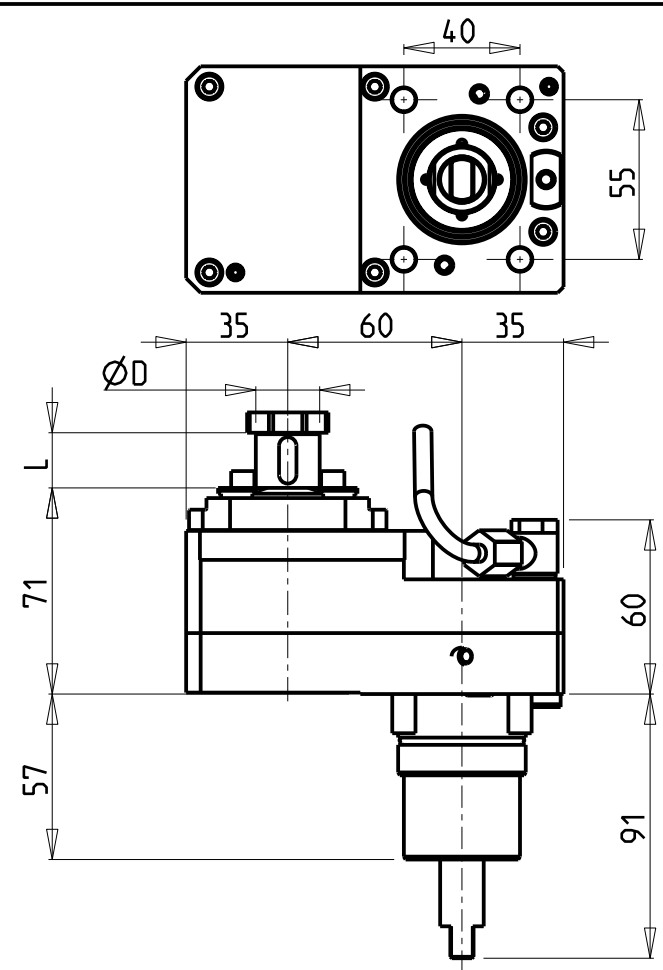

Cod. MT	Mandrino Spindle Spindel	I	RPM	Coppia Max Max Torque Max Drehmoment	Reversibile lato mandrino/contromandrino Reversible sub/main spindle side Umkehrbare Spindel-seite/ Gegenspindel-seite	Lubr.esterna Ext. coolant Aussenkuehlung	D	L	CHIAVI INCLUSE Keys included Schluessel inbegriffen	
NKM1641617	Ø16x17	2:1	3000	40Nm	X	X	16	17	CH_VTCROCE_M08	MNZ0410005
NKM1642219	Ø22x19	2:1	3000	40Nm	X	X	22	19	CH_VTCROCE_M10	MNZ0410005

GOODWAY
MOD: GTZ-1500

MODULO MOTORIZZATO RADIALE RIDOTTO I=2:1 DISASSATO IN Z 60mm
Radial geared-down I=2:1 driven tool re-directed in Z by 60mm
Radial angetriebenes Werkzeug untersetzt I=2:1 achsversetzt in Z um 60mm

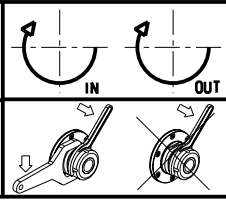

M.T. srl
Via Casino Albini 480
Tel. 0541/956034-957884
Fax 0541/956341
47842 S. GIOVANNI IN M. (RN)
e-mail: mtma@mtmarchetti.com
http://www.mtmarchetti.com



GDW 030-6-20

Subject to change without notice.