

ATTENZIONE - ATTENTION - ACHTUNG

- Per lo smontaggio degli utensili utilizzare sempre la chiave di contrasto come indicato nel manuale d'uso.
- For disassembly of the tools use always the contrast key as mentioned in the user instructions.
- Fuer das Abmontieren der Werkzeuge immer den Gegenschlüssel benutzen wie in der Bedienungsanleitung erwaeht.

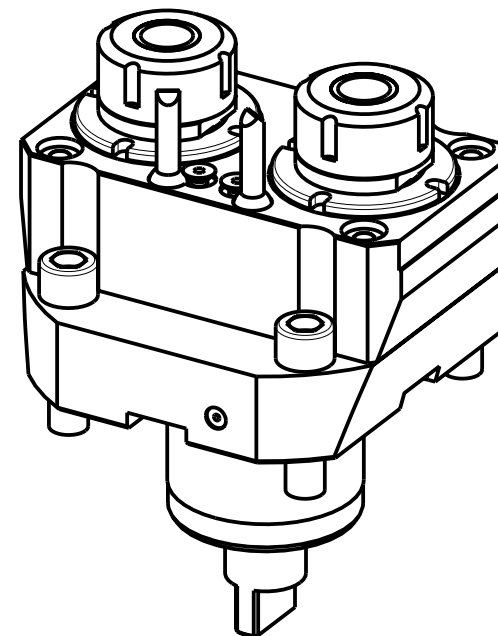
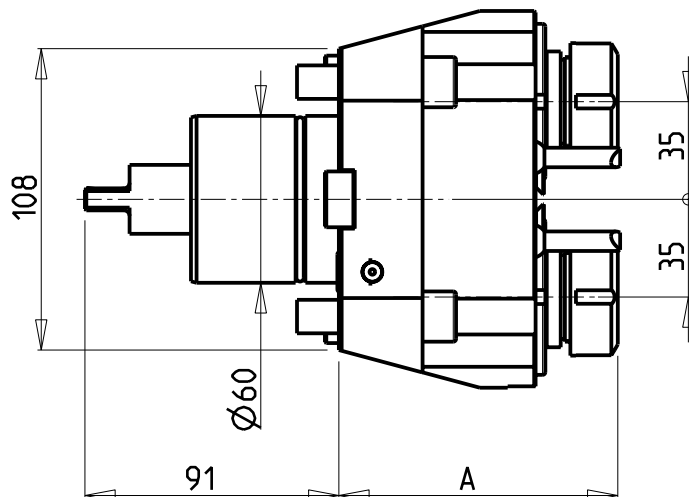
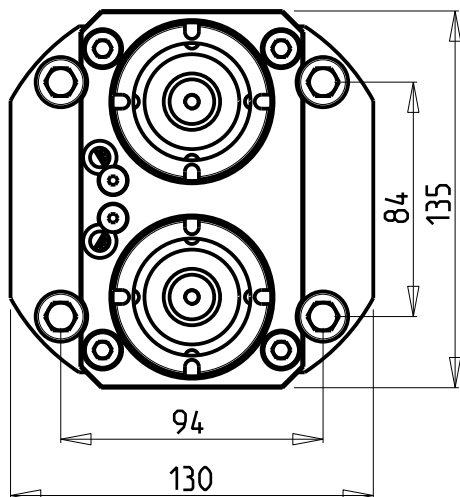

Cod. MT	Mandrino Spindel Spindel	I	RPM	Coppia Max Max Torque Max Drehmoment	Lubrificazione int. Coolant through Innenkuehlung	Lubrificazione est. Ext. coolant Aussenkuehlung	A	CHIAVI NON INCLUSE Keys not included Schlüssel nicht einbegriffen		
GDW 0140225	ER25	1:1	6000	40Nm	-	X	99.96	CHUB36	CHSTER25	-
GDW 0141225	ER25	1:1	6000	40Nm	P=70bar	X	115.2	CHUB36	CHSTER25	-
GDW 0140325	ERA25	1:1	6000	40Nm	-	X	88.5	CHUB38	CHUB27	CHTAER25ZC •
GDW 0141325	ERA25	1:1	6000	40Nm	P=70bar	X	108.53	CHUB38	CHUB27	-

• Chiave inclusa
• Key included
• Schlüssel inbegriffen

GOODWAY

MOD: GS2000/2600/2800/3000/3300/3600/4000 12ST.

MODULO MOTORIZZATO RADIALE 2 USCITE IN Y
Radial single side twin head driven tool in Y
Radial angetriebenes Werkzeug 2 Ausgaenge in Y

Subject to change without notice.

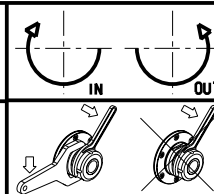

M.T. srl

Via Casino Albini 480
Tel. 0541/956034-957884
Fax 0541/956341
47842 S. GIOVANNI IN M. (RN)
e-mail: mtma@mtmarchetti.com
http://www.mtmarchetti.com



GDW 080-1-00