

ATTENZIONE - ATTENTION - ACHTUNG

- Per lo smontaggio degli utensili utilizzare sempre la chiave di contrasto come indicato nel manuale d'uso.
- For disassembly of the tools use always the contrast key as mentioned in the user instructions.
- Fuer das Abmontieren der Werkzeuge immer den Gegenschlüssel benutzen wie in der Bedienungsanleitung erwäehnt.

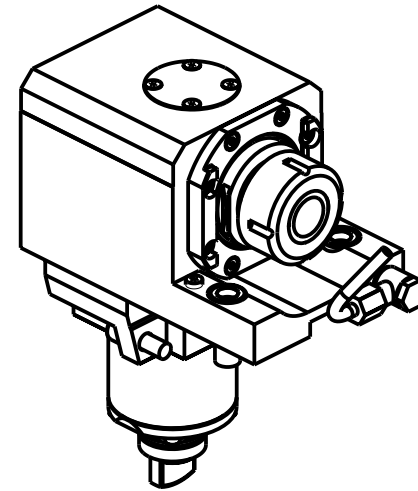
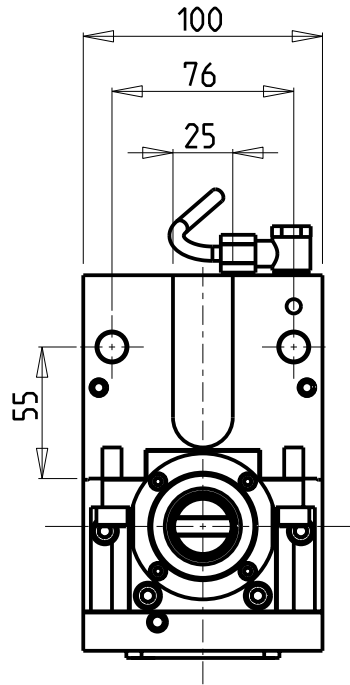
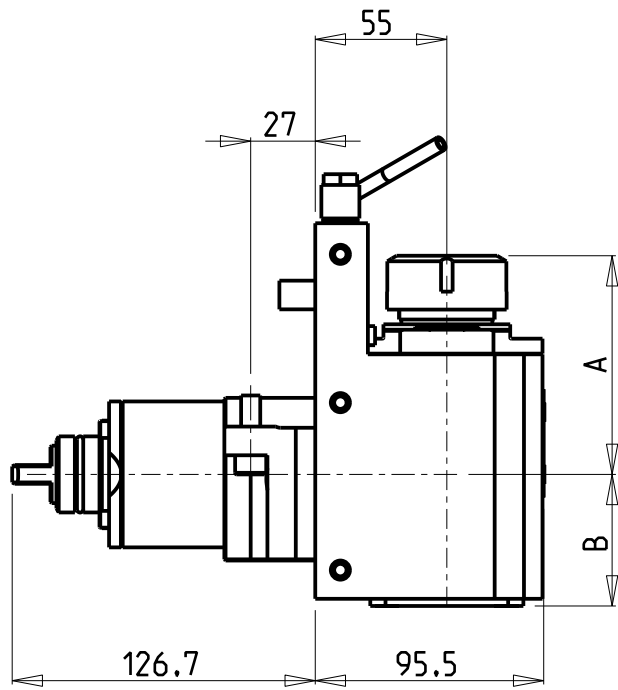

Cod. MT	Mandrino Spindle Spindel	I	RPM	Coppia Max Max Torque Max Drehmoment	Lubrificazione int. Coolant through Innenkuehlung	Lubrificazione est. Ext. coolant Aussenkuehlung	A	B	CHIAVI NON INCLUSE Keys not included Schluessel nicht einbegriffen	
MSL0570132	ER32	1:1	6000	105Nm	-	X	91.41	55	MNZ0410005 *	CHSTER32
MSL0570232	ER32	1:1	6000	105Nm	P=70bar	X	91.41	67.5	MNZ0410005 *	CHSTER32
MSL0570125	ER25	1:1	6000	105Nm	-	X	88.41	55	MNZ0410005 *	CHSTER25
MSL0570225	ER25	1:1	6000	105Nm	P=70bar	X	88.41	67.5	MNZ0410005 *	CHSTER25

- Chiave inclusa
- Key included
- Schluessel inbegriffen

GOODWAY
 MOD: GS200/230/260/280 - GA200/260/280 - GA2000/2600/2800/3000/3300/3600

MODULO MOTORIZZATO ASSIALE PER CONTROMANDRINO H=55mm
 Axial driven tool for subspindle H=55mm
 Axial angetriebenes Werkzeug fuer Gegenspindel H=55mm

Subject to change without notice.

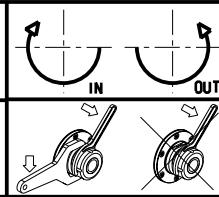

M.T. srl
 Via Casino Albini 480
 Tel. 0541/956034-957884
 Fax 0541/956341
 47842 S. GIOVANNI IN M. (RN)
 e-mail: mtma@mtmarchetti.com
 http://www.mtmarchetti.com



GDW 155-2-10