

CUSCINETTI MAGGIORATI PER LAVORAZIONI PESANTI

Reinforced bearings for
heavy machining

Vergroesserte Lager fuer
schwerere Bearbeitungen

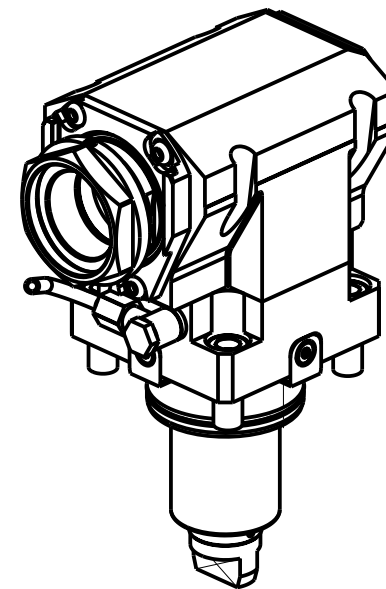

PER PORTAUTENSILI MODULARI MTSK-50 VEDI PAG. TBL300-1-50
FOR MTSK-50 QUICK CHANGE TOOLHOLDERS CLAMPINGS SEE PAGE TBL300-1-50
FUER MTSK-50 MODULARE WERKZEUGAUFNAHMEN SIEHE SEITE TBL300-1-50

Cod. MT	Mandrino Spindle Spindel	I	RPM	Coppia Max Max Torque Max Drehmoment	Reversibile lato mandrino/contromandrino Reversible sub/main spindle side Umkehrbare Spindel-seite/ Gegenspindel-seite	Lubr.interna Coolant through Innenkuehlung	Lubr.esterna Ext. coolant Aussenkuehlung	B	CHIAVI NON INCLUSE Keys not included Schluessel nicht einbegriffen	
DW 02190150	MTSK-50	1:1	6000	110Nm	X	-	X	56.5	CHUB55	OKU0650004 •
DW 02190250	MTSK-50	1:1	6000	110Nm	X	P=70bar	X	67.5	CHUB55	OKU0650004 •

- Chiave inclusa
- Key included
- Schluessel inbegriffen

GOODWAY

MOD: GTX2000/2600 12ST. - GTZ2000/2600 12ST. - GS2000/2800/3300 16ST. - GMT2000 - GMS2000 15ST. - GLS2800/3300 12ST.

MODULO MOTORIZZATO ASSIALE MAGGIORATO MTSK H=85mm
Axial MTSK reinforced driven tool H=85mm
Axial MTSK angetriebenes Werkzeug vergroessert H=85mm

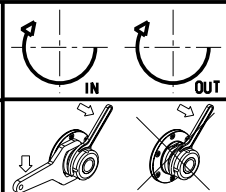

M.T. srl
Via Casino Albini 480
Tel. 0541/956034-957884
Fax 0541/956341
47842 S. GIOVANNI IN M. (RN)
e-mail: mtma@mtmarchetti.com
http://www.mtmarchetti.com



GDW 170-4-20-K

Subject to change without notice.