

ATTENZIONE - ATTENTION - ACHTUNG

- VERIFICARE LE MISURE DI INGOMBRO PER POSSIBILE INTERFERENZA SU ALCUNI MODELLI DI MACCHINE
- Please check the overall sizes for possible interferences on some machine models
- Bitte überprüfen sie das ausmass um mögliche interferenzen auf einigen maschinen modellen zu vermeiden

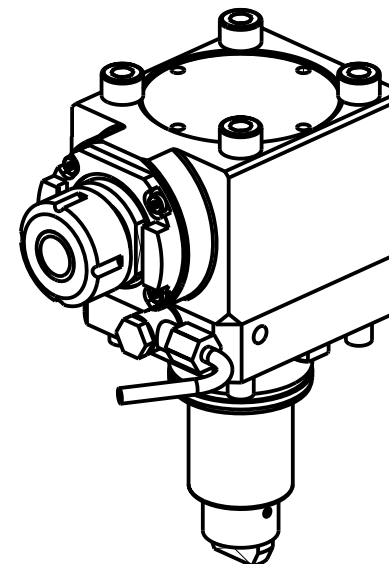
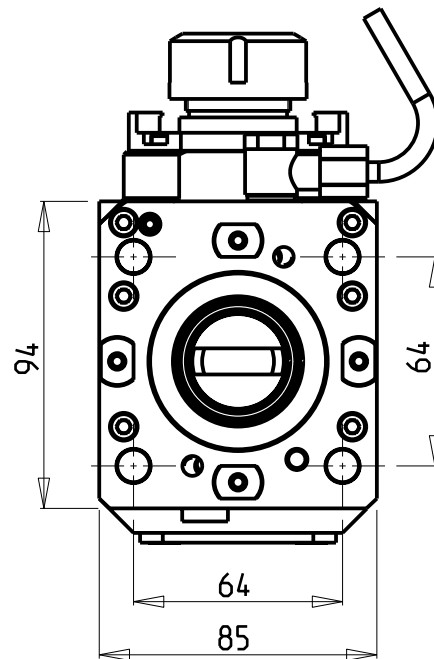
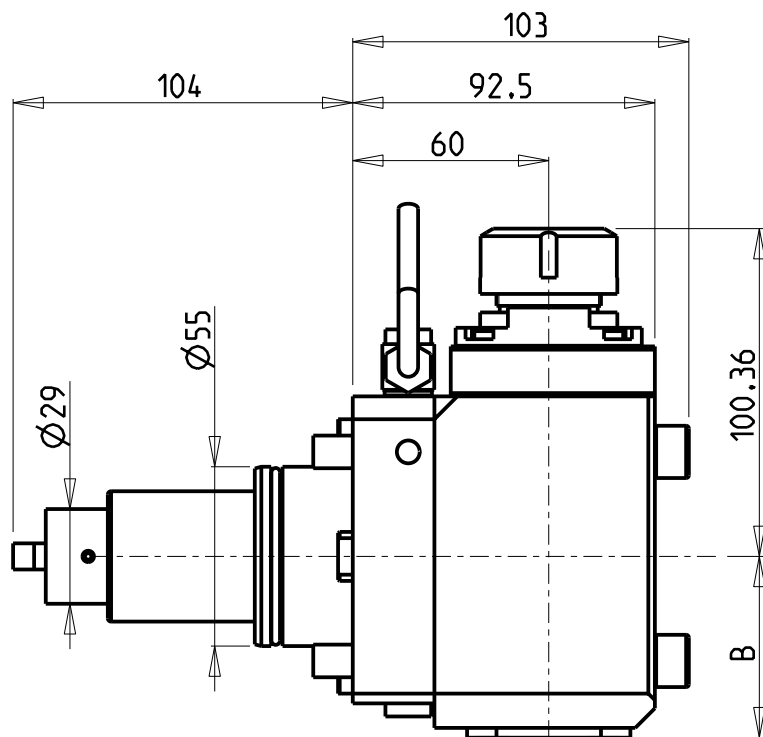

Cod. MT	Mandrino Spindel Spindel	I	RPM	Coppia Max Max Torque Max Drehmoment	Reversibile lato mandrino/contromandrino Reversible sub/main spindle side Umkehrbare Spindel-seite/ Gegenspindel-seite	Lubrificazione int. Coolant through Innenkuehlung	Lubrificazione est. Ext. coolant Aussenkuehlung	B	CHIAVI NON INCLUSE Keys not included Schlüssel nicht einbegriffen	
0891225	ER25	1:2	12000	30Nm	X	-	X	55.5	CHSTER25	SAU0070027 ■
0891325	ER25	1:2	12000	30Nm	X	P=70bar	X	66.5	CHSTER25	SAU0070027 ■

- Chiave inclusa
- Key included
- Schlüssel einbegriffen

GOODWAY
 MOD: GTX2000/2600 16ST. - GTZ2000/2600 16ST.

MODULO MOTORIZZATO ASSIALE MOLTIPLICATO I=1:2 H=60mm
 Axial geared-up I=1:2 driven tool H=60mm
 Axial angetriebenes Werkzeug uebersetzt I=1:2 H=60mm

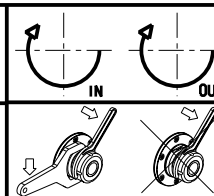

M.T. srl
 Via Casino Albini 480
 Tel. 0541/956034-957884
 Fax 0541/956341
 47842 S. GIOVANNI IN M. (RN)
 e-mail: mtma@mtmarchetti.com
 http://www.mtmarchetti.com

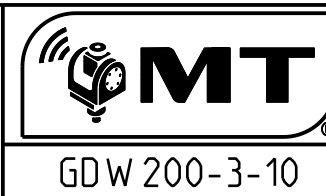

Subject to change without notice.

09/2024