

**ATTENZIONE - ATTENTION - ACHTUNG**

- VERIFICARE LE MISURE DI INGOMBRO PER POSSIBILE INTERFERENZA SU ALCUNI MODELLI DI MACCHINE
- Please check the overall sizes for possible interferences on some machine models
- Bitte überprüfen sie das ausmass um mögliche interferenzen auf einigen maschinen modellen zu vermeiden

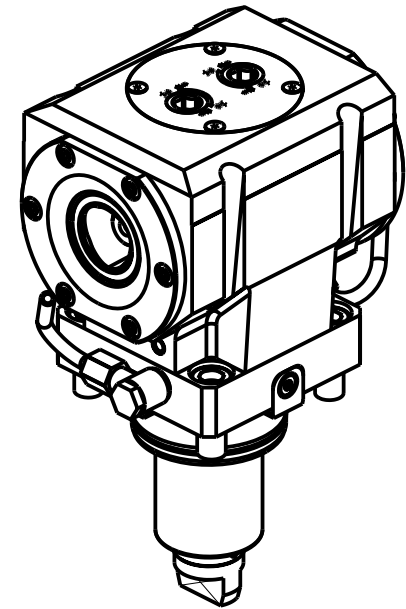

Cod. MT	TAGLIA Size Masse	I	RPM	Coppia Max Max Torque Max Drehmoment	Reversibile lato mandrino/contromandrino Reversible sub/main spindle side Umkehrbare Spindelseite/ Gegenspindelseite	Lubr.esterna Ext. coolant Aussenkuehlung
DW03140240	C4+C4	1:1	6000	100Nm	X	X

**GOODWAY**

MOD: GTX2000/2600 12ST. - GTZ2000/2600 12ST. - GS2000/2800/3300 16ST. - GMT2000 - GMS2000 15ST. - GLS2800/3300 12ST.

MODULO MOTORIZZATO ASSIALE BISPORGENTE MT CAPTO H=85mm

Axial opposite face twin driven tool MT CAPTO H=85mm

Axial angetriebenes Werkzeug halb vorspringend mit MT CAPTO H=85mm

Subject to change without notice.

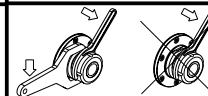

**M.T. srl**

Via Casino Albini 480  
Tel. 0541/956034-957884  
Fax 0541/956341  
47842 S. GIOVANNI IN M. (RN)  
e-mail: mtma@mtmarchetti.com  
http://www.mtmarchetti.com



**GDW 240-D-41**