

ATTENZIONE - ATTENTION - ACHTUNG

- VERIFICARE LE MISURE DI INGOMBRO PER POSSIBILE INTERFERENZA SU ALCUNI MODELLI DI MACCHINE
- Please check the overall sizes for possible interferences on some machine models
- Bitte überprüfen sie das ausmass um mögliche interferenzen auf einigen maschinen modellen zu vermeiden

ATTENZIONE - ATTENTION - ACHTUNG

- Con l'utensile orientato a 90°, non è possibile eseguire lavorazioni a centro-pezzo!
- It is not possible to make machining operations at the center of the part with tool oriented at 90°
- Mit einem Werkzeug um 90° orientiert, ist es nicht möglich, Verarbeitung von der Werkzeug-Mitte auszuführen.

ATTENZIONE - ATTENTION - ACHTUNG

- Per lo smontaggio degli utensili utilizzare sempre la chiave di contrasto come indicato nel manuale d'uso.
- For disassembly of the tools use always the contrast key as mentioned in the user instructions.
- Für das Abmontieren der Werkzeuge immer den Gegenschlüssel benutzen wie in der Bedienungsanleitung erwähnt.

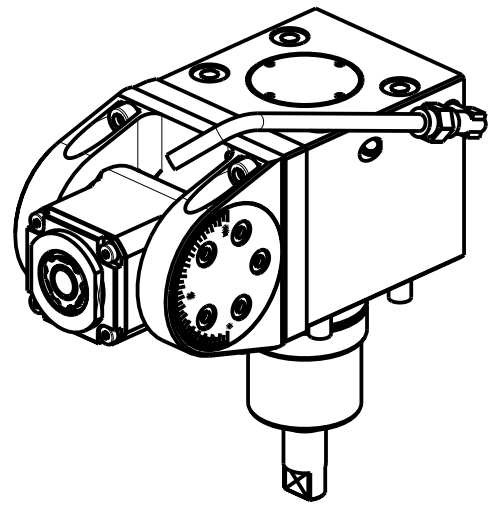

Cod. MT	Mandrino Spindle Spindel	I	RPM	Coppia Max Max Torque Max Drehmoment	Reversibile lato mandrino/contromandrino Reversible sub/main spindle side Umkehrbare Spindel-seite/ Gegenspindel-seite	Lubrificazione int. Coolant through Innenkuehlung	Lubrificazione est. Ext. coolant Aussenkuehlung	CHIAVI INCLUSE Keys included Schluessel inbegriffen		
								CHUB19_SP3	CHUB32	CHTAER16ZC
NKM0670316	ERA16	1:1	6000	20Nm	X	-	X	CHUB19_SP3	CHUB32	CHTAER16ZC
NKM0670416	ERA16	1:1	6000	20Nm	X	P=70bar	X	CHUB19_SP3	CHUB32	CHTAER16ZC

GOODWAY
MOD: GTZ-1500

MODULO MOTORIZZATO ORIENTABILE ±90° H=35mm
±90° adjustable angle driven tool H=35mm
Angetriebenes Werkzeug schwenkbar ±90° H=35mm

Subject to change without notice.

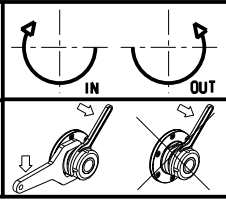

M.T. srl
Via Casino Albini 480
Tel. 0541/956034-957884
Fax 0541/956341
47842 S. GIOVANNI IN M. (RN)
e-mail: mtma@mtmarchetti.com
http://www.mtmarchetti.com



GDW 337-6-00