

ATTENZIONE - ATTENTION - ACHTUNG

- E' consigliato l'utilizzo su torni dotati di controllo dell'asse Y
- It is recommended to use lathes with the required control of the Y-axis.
- Es ist empfehlenswert Drehbänke, ausgerüstet mit Kontrolle der Y-Achse, zu gebrauchen.

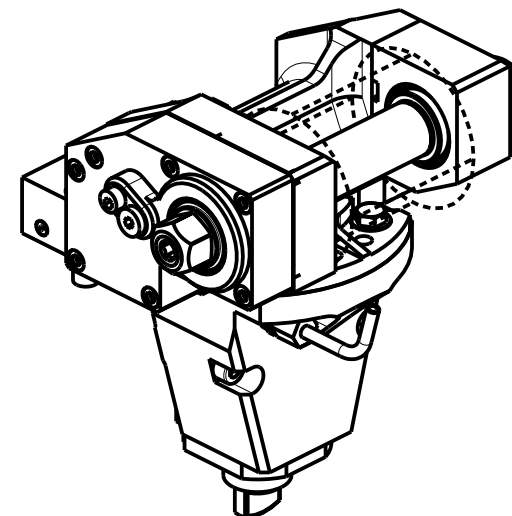

PER ALBERI E DISTANZIALI VEDI PAG. TBL250-1-00
 FOR SHAFT END SPACER SEE PAGE TBL250-1-00
 FUER DORN UND ABSTANDSSTUECK SEITE TBL250-1-00

DOTAZIONI - SUPPLIED WITH - AUSSTATTUNG

- mm / inch
- N°1 ALBERO + DISTANZIALI
 - N°1 SHAFT + SPACER
 - N°1 DORN + ABSTANDSSTUECK

-LA FUNZIONE DI POLIGONATURA/DENTATURA DEVE ESSERE INSTALLATA SULLA MACCHINA
 -POLYGON CUTTING/GEAR HOBBING FUNCTION MUST BE INSTALLED ON THE MACHINE
 -DIE FUNKTION FÜR POLYGON-BZW. VERZÄHNUNGSFRÄSEN MUSS AUF DER MASCHINE FREIGESCHALTET WERDEN

Cod. MT	I	RPM max	Coppia Max Max Torque Max Drehmoment	Lubrificazione est. Ext. coolant Aussenkuehlung	D (mm)	D (Inch)	CHIAVI INCLUSE Keys included Schlüssel inbegriffen		
							CHUB24	CHUB13	CHESL08
M0081100	1:1	6000	60Nm	X	16-22-27-32	3/4"-1"-1 1/4"	CHUB24	CHUB13	CHESL08
M0082100	2:1	3000	80Nm	X	16-22-27-32	3/4"-1"-1 1/4"	CHUB24	CHUB13	CHESL08

GOODWAY

MOD: GS200/230/260/280 - GA200/260/280 - GA2000/2600/2800/3000/3300/3600

MODULO MOTORIZZATO PORTACREATORE

Driven gear hobber

Angetriebenes Zahnradwaeltzraes-Werkzeug

Subject to change without notice.

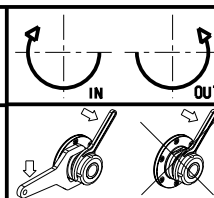

M.T. srl

Via Casino Albini 480
 Tel. 0541/956034-957884

Fax 0541/956341

47842 S. GIOVANNI IN M. (RN)

e-mail: mtma@mtmarchetti.com

http://www.mtmarchetti.com



GDW 340-2-00