

-LA FUNZIONE DI POLIGONATURA/DENTATURA DEVE ESSERE INSTALLATA SULLA MACCHINA
 -POLYGON CUTTING/GEAR HOBBING FUNCTION MUST BE INSTALLED ON THE MACHINE
 -DIE FUNKTION FÜR POLYGON-BZW. VERZÄHNUNGSFRÄSEN MUSS AUF DER MASCHINE FREIGESCHALTET WERDEN

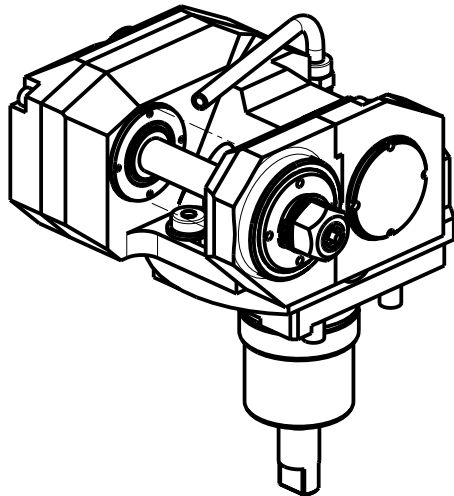

ATTENZIONE - ATTENTION - ACHTUNG

- VERIFICARE LE MISURE DI INGOMBRO PER POSSIBILE INTERFERENZA
- Please check the overall sizes for possible interferences
- Bitte überprüfen sie das Ausmass um mögliche Interferenzen zu vermeiden

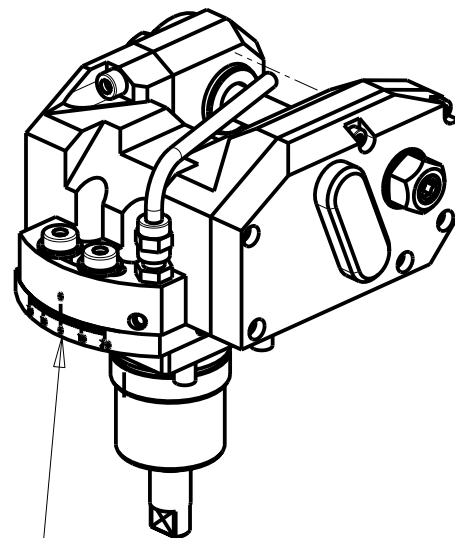

INCLINAZIONE
 REGOLABILE $\pm 20^\circ$

Cod. MT	i	RPM max	Coppia Max Max Torque Max Drehmoment	Lubrificazione est. Ext. coolant Auslenkuehlung	D (mm)	CHIAVI INCLUSE Keys included Schluessel inbegriffen				
NKM1071116	1:1	6000	30Nm	X	16	CHUB19	CHESL06	CHESL05	-	-
NKM1071113	1:1	6000	30Nm	X	13	CHUB19	CHESL06	CHESL05	-	-
NKM1071110	1:1	6000	30Nm	X	10	CHUB19	CHESL06	CHESL05	-	CHUB17
NKM1071108	1:1	6000	30Nm	X	8	CHUB19	CHESL06	CHESL05	CHESL04	CHUB13
NKM1071155	1:1	6000	30Nm	X	1/2"	CHUB19	CHESL06	CHESL05	-	-
NKM1072116	2:1	3000	50Nm	X	16	CHUB19	CHESL06	CHESL05	-	-
NKM1072113	2:1	3000	50Nm	X	13	CHUB19	CHESL06	CHESL05	-	-
NKM1072110	2:1	3000	50Nm	X	10	CHUB19	CHESL06	CHESL05	-	CHUB17
NKM1072108	2:1	3000	50Nm	X	8	CHUB19	CHESL06	CHESL05	CHESL04	CHUB13
NKM1072155	2:1	3000	50Nm	X	1/2"	CHUB19	CHESL06	CHESL05	-	-

GOODWAY
 MOD: GTZ-1500

MODULO MOTORIZZATO PORTACREATORE
 Driven gear hobber
 Angetriebenes Zahnradwaeltzraes-Werkzeug

Subject to change without notice.

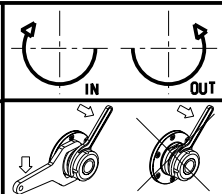

M.T. srl
 Via Casino Albini 480
 Tel. 0541/956034-957884
 Fax 0541/956341
 47842 S. GIOVANNI IN M. (RN)
 e-mail: mtma@mtmarchetti.com
 http://www.mtmarchetti.com

