

-COMPATIBILE CON UTENSILI COMMERCIALI AD INSERTI
 -COMPATIBLE WITH COMMERCIAL INSERT CUTTING-TOOLS
 -KOMPATIBEL MIT HANDELSÜBLICHEN SCHNEIDWERKZEUGEN

ATTENZIONE - ATTENTION - ACHTUNG

- VERIFICARE LE MISURE DI INGOMBRO PER POSSIBILE INTERFERENZA SU ALCUNI MODELLI DI MACCHINE
- Please check the overall sizes for possible interferences on some machine models
- Bitte überprüfen sie das ausmass um mögliche interferenzen auf einigen maschinen modellen zu vermeiden

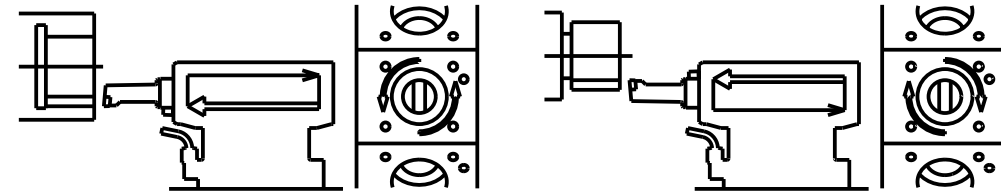
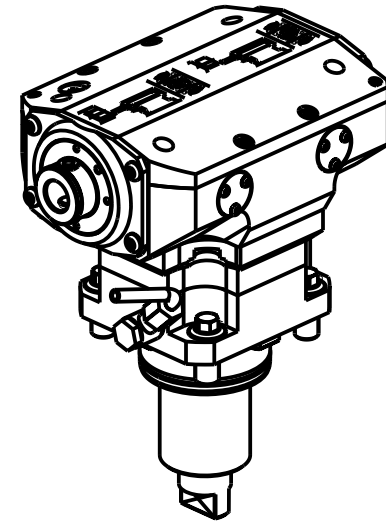
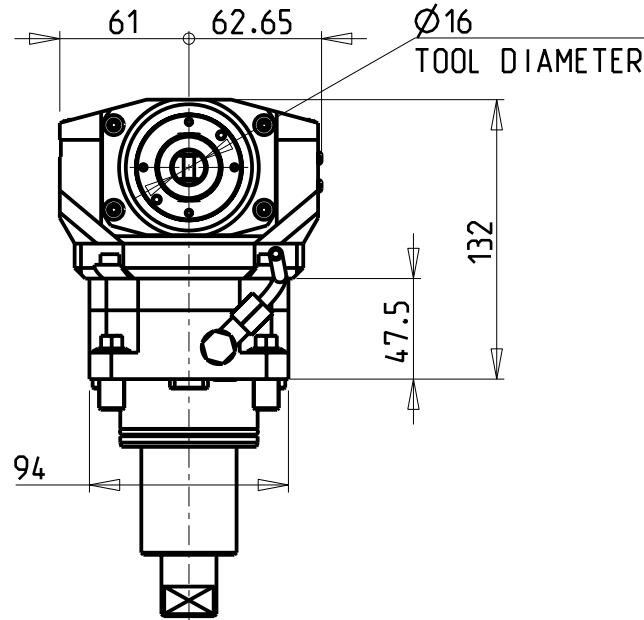
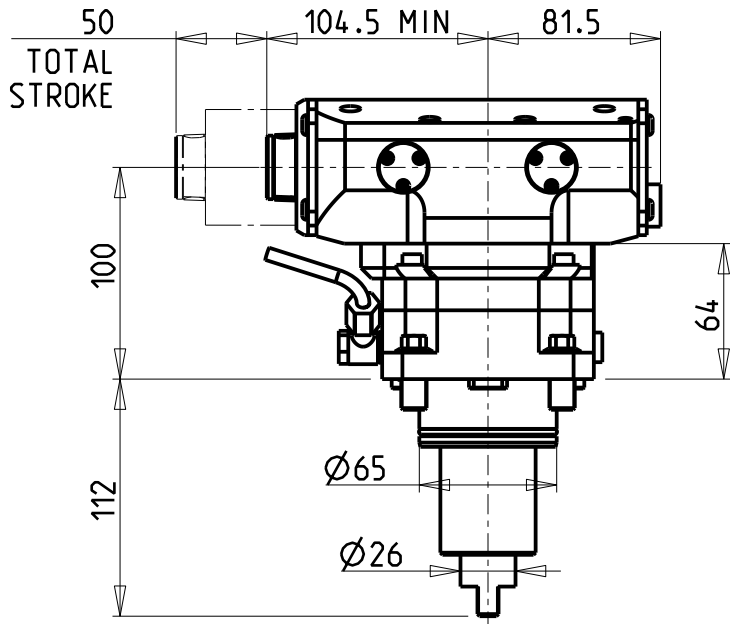
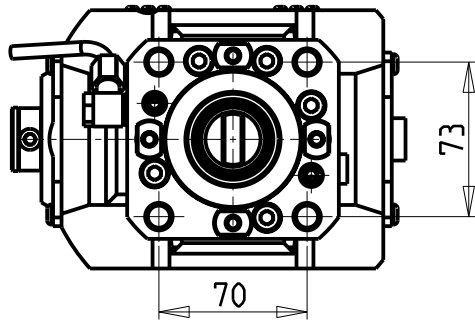

Cod. MT	I	RPM MAX	Reversibile lato mandrino/contromandrino Reversible sub/main spindle side Umkehrbare Spindelseite/ Gegenspindelseite	Lubr. esterna Ext. coolant Aussenkuehlung
DW 04121100	1:1	500	X	X

GOODWAY

MOD: GTX2000/2600 12ST. - GTZ2000/2600 12ST. - GS2000/2800/3300 16ST. - GMT2000 - GMS2000 15ST.
 GLS2800/3300 12ST. - GTH2000/2600 12ST.

MODULO MOTORIZZATO BROCCIAATORE CORSA 50mm H=100mm
 Driven Broaching Toolholder 50mm stroke H=100mm
 Angetriebenes Nutzenstoßwerkzeug 50mm Hub H=100mm

M.T. srl

Via Casino Albini 480
 Tel. 0541/956034-957884
 Fax 0541/956341
 47842 S. GIOVANNI IN M. (RN)
 e-mail: mtma@mtmarchetti.com
 http://www.mtmarchetti.com



GDW 360-4-60

Subject to change without notice.

09/2024