

-COMPATIBILE CON UTENSILI COMMERCIALI AD INSERTI
 -COMPATIBLE WITH COMMERCIAL INSERT CUTTING-TOOLS
 -KOMPATIBEL MIT HANDELSÜBLICHEN SCHNEIDWERKZEUGEN

ATTENZIONE - ATTENTION - ACHTUNG

- VERIFICARE LE MISURE DI INGOMBRO PER POSSIBILE INTERFERENZA SU ALCUNI MODELLI DI MACCHINE
- Please check the overall sizes for possible interferences on some machine models
- Bitte überprüfen sie das ausmass um mögliche interenzen auf einigen maschinen modellen zu vermeiden

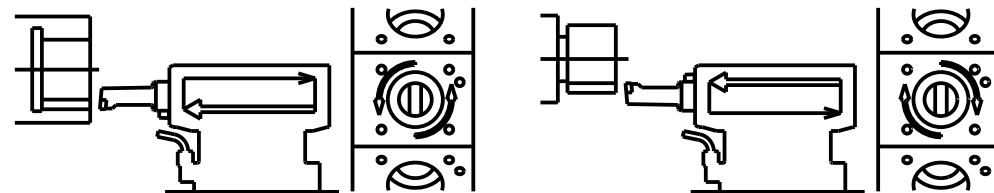
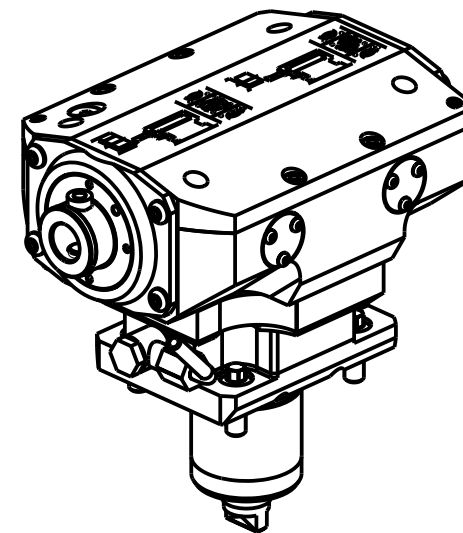

Cod. MT	I	RPM MAX	Reversibile lato mandrino/contromandrino Reversible sub/main spindle side Umkehrbare Spindelseite/ Gegenspindelseite	Lubr. esterna Ext. coolant Aussenkuehlung
MYA0390100	1:1	500	X	X

GOODWAY

MOD: GLS-150/200M/Y - GLS-1500/2000LY/LYS - GTS-150MMX/XY - GTW-1500

MODULO MOTORIZZATO BROCCIAITORE CORSA 50mm H=90mm

Driven Broaching Toolholder 50mm stroke H=90mm

Angetriebenes Nutzenstoßwerkzeug 50mm Hub H=90mm

M.T. srl

Via Casino Albini 480
 Tel. 0541/956034-957884
 Fax 0541/956341

47842 S. GIOVANNI IN M. (RN)
 e-mail: mtma@mtmarchetti.com
 http://www.mtmarchetti.com



GDW 360-5-50

Subject to change without notice.

09/2024