

ATTENZIONE - ATTENTION - ACHTUNG

- VERIFICARE LE MISURE DI INGOMBRO PER POSSIBILE INTERFERENZA SU ALCUNI MODELLI DI MACCHINE
- Please check the overall sizes for possible interferences on some machine models
- Bitte überprüfen sie das ausmass um mögliche interferenzen auf einigen maschinen modellen zu vermeiden

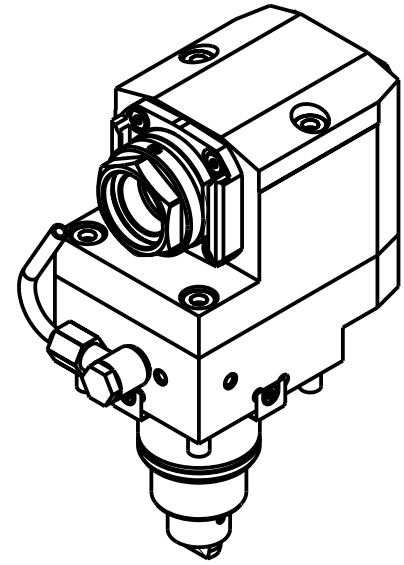

PER PORTAUTENSILI MODULARI MTSK-32 VEDI PAG. TBL300-1-32
 FOR MTSK-32 QUICK CHANGE TOOLHOLDERS CLAMPINGS SEE PAGE TBL300-1-32
 FUER MTSK-32 MODULARE WERKZEUGAUFNAHMEN SIEHE SEITE TBL300-1-32

Cod. MT	Mandrino Spindel Spindel	I	RPM	Coppia Max Max Torque Max Drehmoment	Reversibile lato mandrino/contromandrino Reversible sub/main spindle side Umkehrbare Spindel-seite/ Gegenspindel-seite	Lubr.interna Coolant through Innenkuehlung	Lubrificazione est. Ext. coolant Aussenkuehlung	B	CHIAVI NON INCLUSE Keys not included Schluessel nicht einbegriffen	
DW02300132	MTSK-32	1:1	6000	35Nm	X	-	X	73.5	CHUB36	OKU0290009 ▪
DW02300232	MTSK-32	1:1	6000	35Nm	X	P=70bar	X	83.5	CHUB36	OKU0290009 ▪

- Chiave inclusa
- Key included
- Schluessel inbegriffen

HAAS
 MOD: ST10/15Y (BMT45)

MODULO MOTORIZZATO ASSIALE ARRETRATO MTSK H=85mm
 Axial MTSK rear-set driven tool H=85mm
 Axial MTSK angetriebenes Werkzeug zurueckversetzt H=85mm

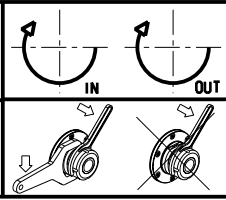

M.T. srl
 Via Casino Albini 480
 Tel. 0541/956034-957884
 Fax 0541/956341
 47842 S. GIOVANNI IN M. (RN)
 e-mail: mtma@mtmarchetti.com
 http://www.mtmarchetti.com



HAS180-5-10-K

Subject to change without notice.