

INCLINAZIONE
REGOLABILE $\pm 30^\circ$

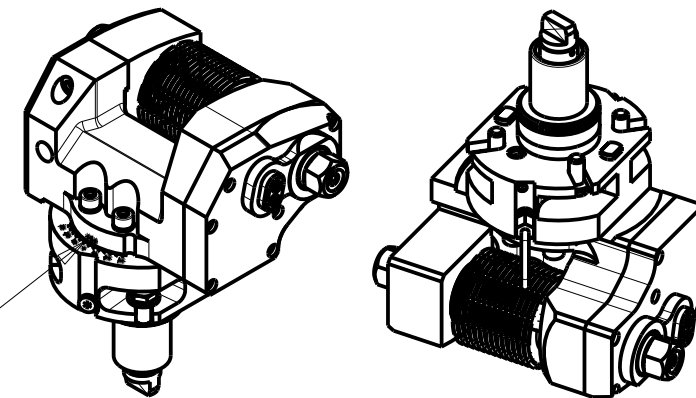

ATTENZIONE - ATTENTION - ACHTUNG

- VERIFICARE LE MISURE DI INGOMBRO PER POSSIBILE INTERFERENZA SU ALCUNI MODELLI DI MACCHINE
- Please check the overall sizes for possible interferences on some machine models
- Bitte überprüfen sie das ausmass um mögliche interferenzen auf einigen maschinen modellen zu vermeiden

-LA FUNZIONE DI POLIGONATURA/DENTATURA DEVE ESSERE INSTALLATA SULLA MACCHINA
-POLYGON CUTTING/GEAR HOBBING FUNCTION MUST BE INSTALLED ON THE MACHINE
-DIE FUNKTION FÜR POLYGON-BZW. VERZÄHNUNGSFRÄSEN MUSS AUF DER MASCHINE FREIGESCHALTET WERDEN

DOTAZIONI - SUPPLIED WITH - AUSSTATTUNG

- mm / inch
- N°1 ALBERO + DISTANZIALI
 - N°1 SHAFT + SPACER
 - N°1 DORN + ABSTANDSSTUECK

PER ALBERI E DISTANZIALI VEDI PAG. TBL250-1-00
FOR SHAFT END SPACER SEE PAGE TBL250-1-00
FUER DORN UND ABSTANDSSTUECK SEITE TBL250-1-00

| Cod. MT | I | RPM | Coppia Max Max Torque Max Drehmoment | Lubrificazione est. Ext. coolant Aussenkuehlung | D (mm) | D (Inch) | CHIAVI INCLUSE Keys included Schluessel inbegriffen | | | |
|------------|-----|------|--|---|-------------|----------------|---|--------|---------|----------------------|
| | | | | | | | CHUB30 | CHUB19 | CHESL08 | CHUB24 (Ø16 / Ø3/4") |
| DW00031100 | 1:1 | 6000 | 90Nm | X | 16-22-27-32 | 3/4"-1"-1 1/4" | CHUB30 | CHUB19 | CHESL08 | CHUB24 (Ø16 / Ø3/4") |
| DW00032100 | 2:1 | 3000 | 110Nm | X | 16-22-27-32 | 3/4"-1"-1 1/4" | CHUB30 | CHUB19 | CHESL08 | CHUB24 (Ø16 / Ø3/4") |

HAAS

MOD: ST20/25/28/30/35 (BMT65) - DS30 (BMT65)

MODULO MOTORIZZATO PORTACREATORE MAGGIORATO

Reinforced driven gear hobber

Angetriebenes Zahnradwaelzfraes-Werkzeug vergroessert

Subject to change without notice.

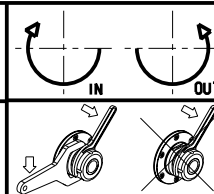

M.T. srl

Via Casino Albini 480
Tel. 0541/956034-957884
Fax 0541/956341

47842 S. GIOVANNI IN M. (RN)
e-mail: mtma@mtmarchetti.com
http://www.mtmarchetti.com



HAS340-4-60

09/2024