

### ATTENZIONE - ATTENTION - ACHTUNG

- Con l'utensile orientato a  $\pm 90^\circ$ , non è possibile eseguire lavorazioni a centro-pezzo!
- It is not possible to make machining operations at the center of the part with tool oriented at  $\pm 90^\circ$
- Mit einem Werkzeug um  $\pm 90^\circ$  orientiert, ist es nicht möglich, Verarbeitung von der Werkzeug-Mitte auszuführen.

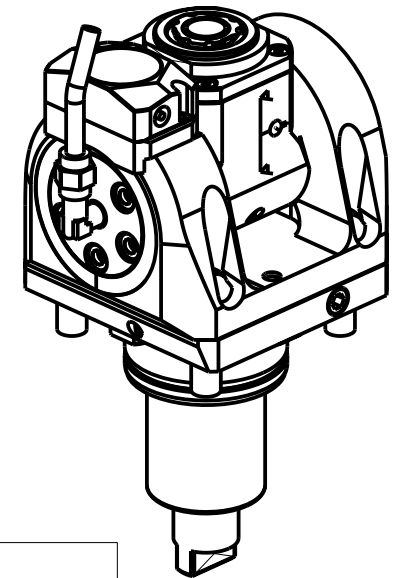

Cod. MT	Mandrino Spindle Spindel	I	RPM	Coppia Max Max Torque Max Drehmoment	Reversibile lato mandrino/contromandrino Reversible sub/main spindle side Umkehrbare Spindelsete/Gegenspindelsete	Lubrificazione int. Coolant through Innenkuehlung	Lubrificazione est. Ext. coolant Aussenkuehlung	CHIAVI INCLUSE Keys included Schluessel inbegriffen			
								CHUB22	CHUB36	CHTAER20ZC	CHESL07
DW00665120	ERA20	1:1	6000	30Nm	X	-	X	CHUB22	CHUB36	CHTAER20ZC	CHESL07
DW00665220	ERA20	1:1	6000	30Nm	X	P=70bar	X	CHUB22	CHUB36	CHTAER20ZC	CHESL07

**HARD INGE**

MOD: T-51/65 12ST. - CONQUEST H51 12ST. (BMT55)

MODULO MOTORIZZATO ORIENTABILE  $\pm 90^\circ$  CON NONIO DIGITALE H=47.5mm

$\pm 90^\circ$  adjustable angle driven tool with digital display H=47.5mm

Angetriebenes Werkzeug schwenkbar  $\pm 90^\circ$  mit digital display H=47.5mm

Subject to change without notice.

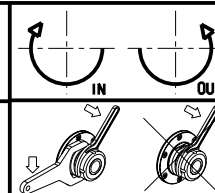

**M.T. srl**

Via Casino Albini 480  
Tel. 0541/956034-957884  
Fax 0541/956341  
47842 S. GIOVANNI IN M. (RN)  
e-mail: mtma@mtmarchetti.com  
http://www.mtmarchetti.com



HRD335-2-01