

ATTENZIONE - ATTENTION - ACHTUNG

- Con l'utensile orientato a 0° o 180°, non è possibile eseguire lavorazioni a centro-pezzo!
- It is not possible to make machining operations at the center of the part with tool oriented at 0° or at 180°.
- Mit einem Werkzeug um 0° oder 180° orientiert, ist es nicht möglich, Verarbeitung von der Werkzeug-Mitte auszuführen.

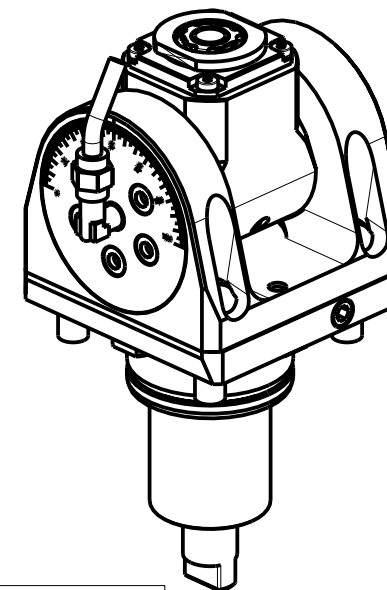

| Cod. MT | Mandrino Spindle Spindel | i | RPM | Coppia Max Max Torque Max Drehmoment | Reversibile lato mandrino/contromandrino Reversible sub/main spindle side Umkehrbare Spindelsete/Gegenspindelsete | Lubrificazione int. Coolant through Innenkuehlung | Lubrificazione est. Ext. coolant Aussenkuehlung | CHIAVI INCLUSE Keys included Schluessel inbegriffen | | | |
|------------|--------------------------|-----|-------|--------------------------------------|---|---|---|---|--------|------------|---------|
| | | | | | | | | CHUB19_SP3 | CHUB32 | CHTAER16ZC | CHESL07 |
| DW00660316 | ERA16 | 1:2 | 12000 | 8Nm | X | - | X | CHUB19_SP3 | CHUB32 | CHTAER16ZC | CHESL07 |
| DW00660416 | ERA16 | 1:2 | 12000 | 8Nm | X | P=70bar | X | CHUB19_SP3 | CHUB32 | CHTAER16ZC | CHESL07 |

HARD INGE

MOD: T-51/65 12ST. - CONQUEST H51 12ST. (BMT55)

MODULO MOTORIZZATO ORIENTABILE +/-90° MOLTIPLICATO I=1:2 H=47.5mm

+/-90° adjustable angle driven tool geared-up I=1:2 H=47.5mm

Angetriebenes Werkzeug schwenkbar +/-90° uebersetzt I=1:2 H=47.5mm

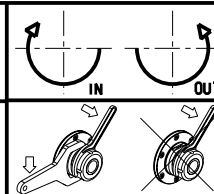

M.T. srl

Via Casino Albini 480
Tel. 0541/956034-957884
Fax 0541/956341

47842 S. GIOVANNI IN M. (RN)
e-mail: mtma@mtmarchetti.com
http://www.mtmarchetti.com



HRD336-2-00

Subject to change without notice.

09/2024