

INCLINAZIONE
REGOLABILE ±15°

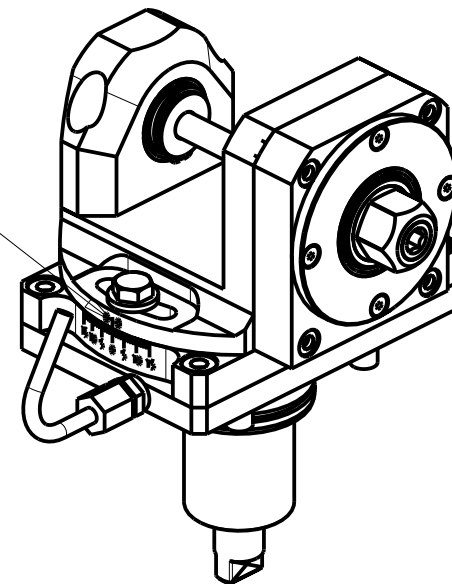

-LA FUNZIONE DI POLIGONATURA/DENTATURA
DEVE ESSERE INSTALLATA SULLA MACCHINA
-POLYGON CUTTING/GEAR HOBGING FUNCTION
MUST BE INSTALLED ON THE MACHINE
-DIE FUNKTION FÜR POLYGON-BZW. VERZÄHNUNGSFRÄSEN
MUSS AUF DER MASCHINE FREIGESCHALTET WERDEN

Cod. MT	i	RPM max	Coppia Max Max Torque Max Drehmoment	Lubrificazione est. Ext. coolant Aussenkuehlung	D (mm)	CHIAVI INCLUSE Keys included Schlüssel inbegriffen					
						C HUB24	C HUB13	C HESL08	C HESL06	C HESL04	-
DW 00051108	1:1	6000	50Nm	X	8	C HUB24	C HUB13	C HESL08	C HESL06	C HESL04	-
DW 00051110	1:1	6000	50Nm	X	10	C HUB24	C HUB17	C HUB13	C HESL08	C HESL06	C HESL05
DW 00051113	1:1	6000	50Nm	X	13	C HUB24	C HUB19	C HUB13	C HESL08	C HESL06	-
DW 00051116	1:1	6000	50Nm	X	16	C HUB24	C HUB13	C HESL08	C HESL06	-	-

HARD INGE
MOD: T-51/65 12ST. - CONQUEST H51 12ST. (BMT55)

MODULO MOTORIZZATO PORTACREATORE RADIALE
Radial driven gear hobber
Radial Angetriebenes Zahnradwaelzfraes-Werkzeug

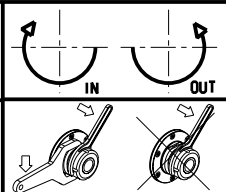

M.T. srl
Via Casino Albini 480
Tel. 0541/956034-957884
Fax 0541/956341
47842 S. GIOVANNI IN M. (RN)
e-mail: mtma@mtmarchetti.com
http://www.mtmarchetti.com

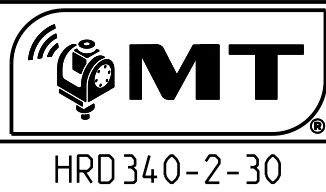

Subject to change without notice.