

-COMPATIBILE CON UTENSILI COMMERCIALI AD INSERTI
 -COMPATIBLE WITH COMMERCIAL INSERT CUTTING-TOOLS
 -KOMPATIBEL MIT HANDELSÜBLICHEN SCHNEIDWERKZEUGEN

ATTENZIONE - ATTENTION - ACHTUNG

- VERIFICARE LE MISURE DI INGOMBRO PER POSSIBILE INTERFERENZA SU ALCUNI MODELLI DI MACCHINE
- Please check the overall sizes for possible interferences on some machine models
- Bitte überprüfen sie das ausmass um mögliche interferenzen auf einigen maschinen modellen zu vermeiden

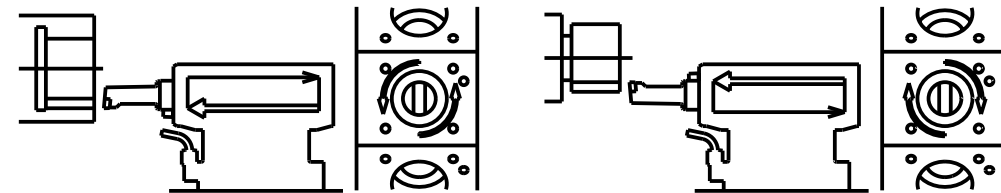
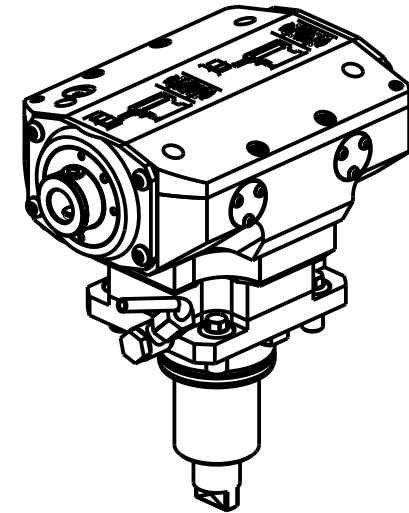
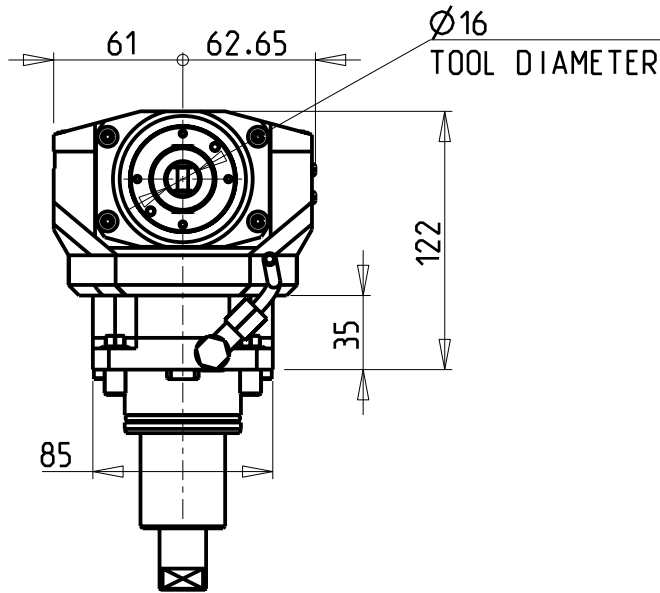
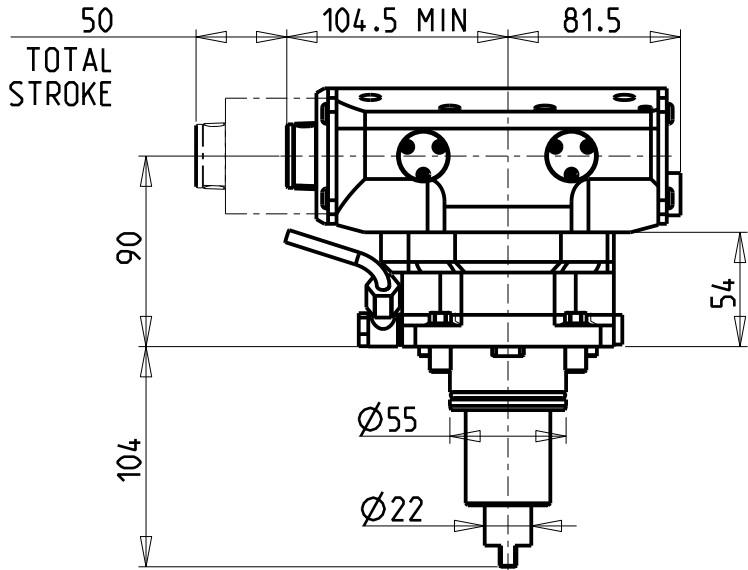
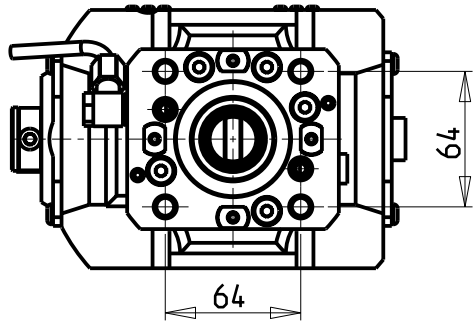

| Cod. MT | I | RPM MAX | Reversibile lato mandrino/contromandrino Reversible sub/main spindle side Umkehrbare Spindelseite/ Gegenspindelseite | Lubr. esterna Ext. coolant Aussenkuehlung |
|--------------|-----|---------|---|---|
| DW 04 110100 | 1:1 | 500 | X | X |

HARD INGE

MOD: T-51/65 12ST. - CONQUEST H51 12ST. (BMT55)

MODULO MOTORIZZATO BROCCIAITORE CORSA 50mm H=90mm

Driven Broaching Toolholder 50mm stroke H=90mm

Angetriebenes Nutzenstoßwerkzeug 50mm Hub H=90mm

Subject to change without notice.

M.T. srl

Via Casino Albini 480
 Tel. 0541/956034-957884
 Fax 0541/956341
 47842 S. GIOVANNI IN M. (RN)
 e-mail: mtma@mtmarchetti.com
 http://www.mtmarchetti.com



HRD 360-2-50