

ATTENZIONE - ATTENTION - ACHTUNG

- VERIFICARE LE MISURE DI INGOMBRO PER POSSIBILE INTERFERENZA SU ALCUNI MODELLI DI MACCHINE
- Please check the overall sizes for possible interferences on some machine models
- Bitte überprüfen sie das ausmass um mögliche interferenzen auf einigen maschinen modellen zu vermeiden

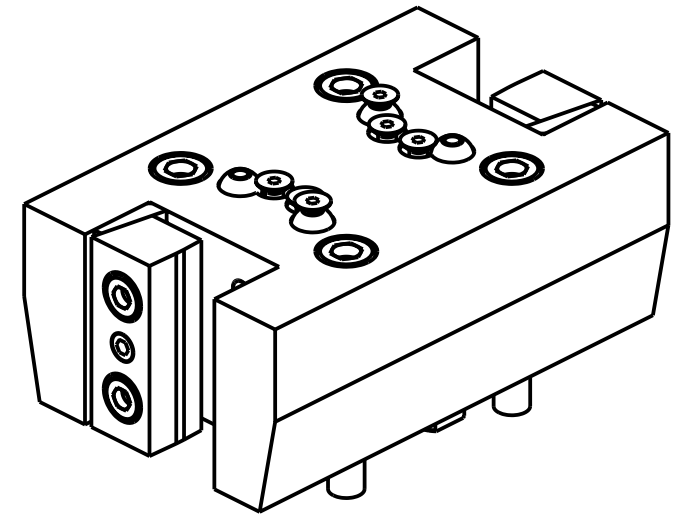
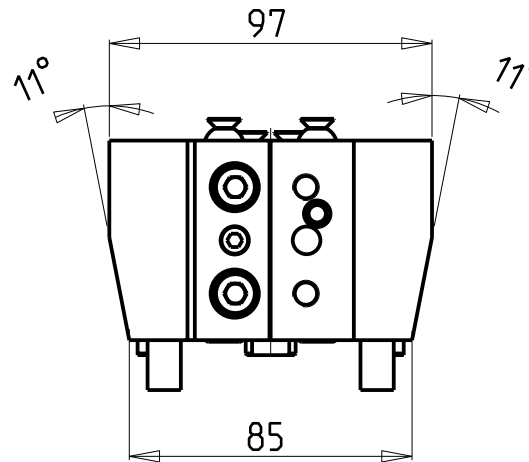
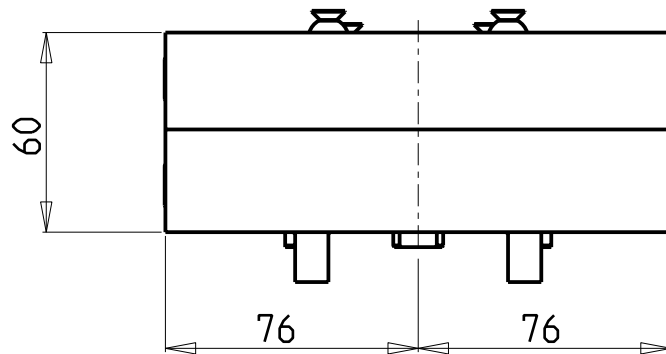
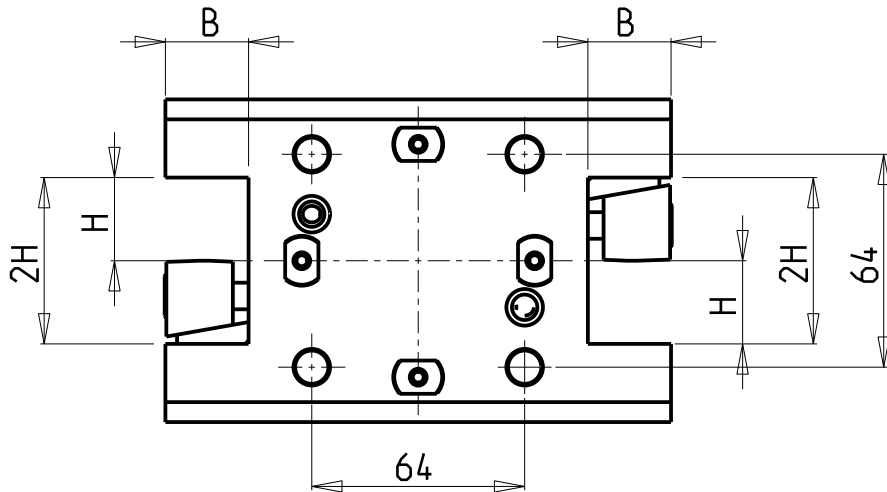

Cod. MT	N°Utensili N°Tools N°Werkzeuge	Reversibile lato mandrino/contromandrino Reversible sub/main spindle side Umkehrbare Spindel-seite/ Gegenspindel-seite	Lubrificazione est. Ext. coolant Auslenkuehlung	Misure Dimensions Masse	B	H	
DW04352500	2	X	X	mm	25	25	NEW

HARD INGE
 MOD: T-51/65 12ST. - CONQUEST H51 12ST. (BMT55)

PORTAUTENSILE RADIALE DOPPIO QD=25mm H=60mm
 Radial double static tool QD=25mm H=60mm
 Radial Doppel-Werkzeughalter QD=25mm H=60mm

Subject to change without notice.

M.T. srl
 Via Casino Albini 480
 Tel. 0541/956034-957884
 Fax 0541/956341
 47842 S. GIOVANNI IN M. (RN)
 e-mail: mtma@mtmarchetti.com
 http://www.mtmarchetti.com



HRD453-2-00