

**CUSCINETTI MAGGIORATI  
PER LAVORAZIONI PESANTI**

Reinforced bearings for  
heavy machining

Vergroesserte Lager fuer  
schwerere Bearbeitungen

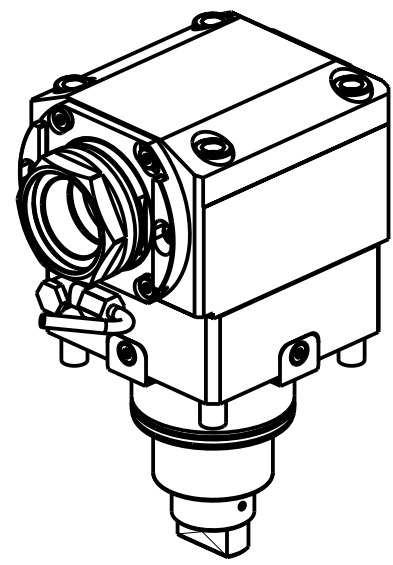

- Chiave inclusa
- Key included
- Schluessel inbegriffen

PER PORTAUTENSILI MODULARI MTSK-50 VEDI PAG. TBL300-1-50  
FOR MTSK-50 QUICK CHANGE TOOLHOLDERS CLAMPINGS SEE PAGE TBL300-1-50  
FUER MTSK-50 MODULARE WERKZEUGAUFNAHMEN SIEHE SEITE TBL300-1-50

Cod. MT	Mandrino Spindle Spindel	I	RPM	Coppia Max Max Torque Max Drehmoment	Reversibile lato mandrino/contromandrino Reversible sub/main spindle side Umkehrbare Spindel-seite/ Gegenspindel-seite	Lubr.interna Coolant through Innenkuehlung	Lubr.esterna Ext. coolant Aussenkuehlung	B	CHIAVI NON INCLUSE Keys not included Schluessel nicht einbegriffen	
DW 02150150	MTSK-50	1:1	6000	140Nm	X	-	X	64	CHUB55	OKU0430007 ▪
DW 02150250	MTSK-50	1:1	6000	140Nm	X	P=70bar	X	76.5	CHUB55	OKU0430007 ▪

**HW ACHEON**  
HI-TECH 550 MC - HI-TECH 650 MC/YMC

MODULO MOTORIZZATO ASSIALE MAGGIORATO MTSK H=90mm  
Axial MTSK reinforced driven tool H=90mm  
Axial MTSK angetriebenes Werkzeug vergroessert H=90mm

Subject to change without notice.

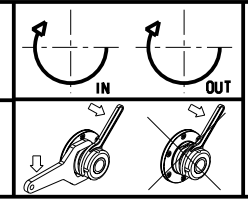

**M.T. srl**  
Via Casino Albini 480  
Tel. 0541/956034-957884  
Fax 0541/956341  
47842 S. GIOVANNI IN M. (RN)  
e-mail: mtma@mtmarchetti.com  
http://www.mtmarchetti.com



**HW C 170-3-20-K**