

**CUSCINETTI MAGGIORATI
PER LAVORAZIONI PESANTI**

Reinforced bearings for heavy machining

Vergroesserte Lager fuer schwerere Bearbeitungen

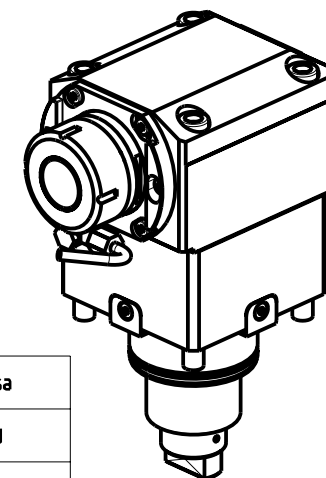

- Chiave inclusa
- Key included
- Schluessel inbegriffen

Cod. MT	Mandrino Spindle Spindel	I	RPM	Coppia Max Max Torque Max Drehmoment	Reversibile lato mandrino/contromandrino Reversible sub/main spindle side Umkehrbare Spindel-seite/ Gegenspindel-seite	Lubrificazione int. Coolant through Innenkuehlung	Lubrificazione est. Ext. coolant Aussenkuehlung	A	A1	A2	B	D	L	CHIAVI NON INCLUDE Keys not included Schluessel nicht einbegriffen	
DW 01340140	ER40	1:1	6000	140Nm	X	-	X	109.7	-	-	64	-	-	CHSTER40	OKU0430007 •
DW 01340240	ER40	1:1	6000	140Nm	X	P=70bar	X	109.7	-	-	76.5	-	-	CHSTER40	OKU0430007 •
DW 01340725	WELDON 25	1:1	6000	140Nm	X	-	X	-	109.5	-	64	-	-	-	-
DW 01340825	WELDON 25	1:1	6000	140Nm	X	P=70bar	X	-	109.5	-	76.5	-	-	-	-
DW 01340522	Ø22x19	1:1	6000	140Nm	X	-	X	-	-	89	64	22	19	CH_VTCROCE_M10 •	OKU0430007 •

HW ACHEON
 HI-TECH 550 MC - HI-TECH 650 MC/YMC - HI-TECH 700 MC (BMT75) - VT550/650 MC

MODULO MOTORIZZATO ASSIALE MAGGIORATO H=110mm
 Axial reinforced driven tool H=110mm
 Axial angetriebenes Werkzeug vergroessert H=110mm

Subject to change without notice.

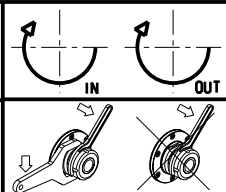

M.T. srl
 Via Casino Albini 480
 Tel. 0541/956034-957884
 Fax 0541/956341
 47842 S. GIOVANNI IN M. (RN)
 e-mail: mtma@mtmarchetti.com
 http://www.mtmarchetti.com

