

## CUSCINETTI MAGGIORATI PER LAVORAZIONI PESANTI

Reinforced bearings for  
heavy machining

Vergroesserte Lager fuer  
schwerere Bearbeitungen

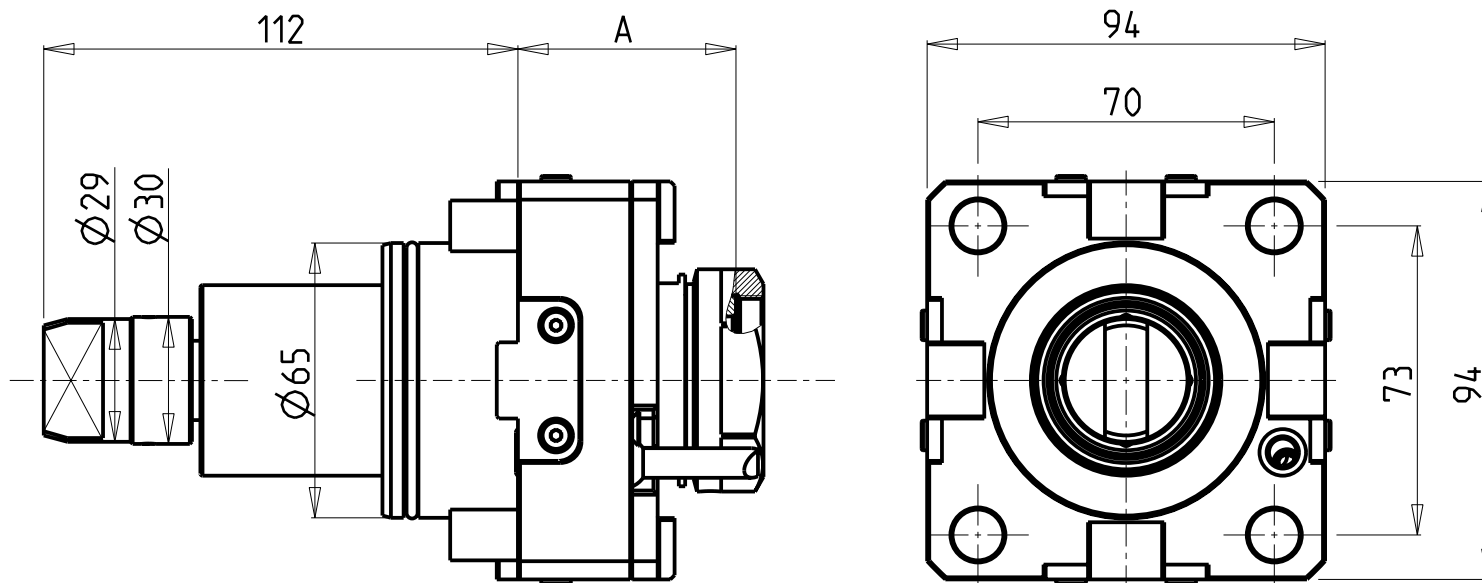
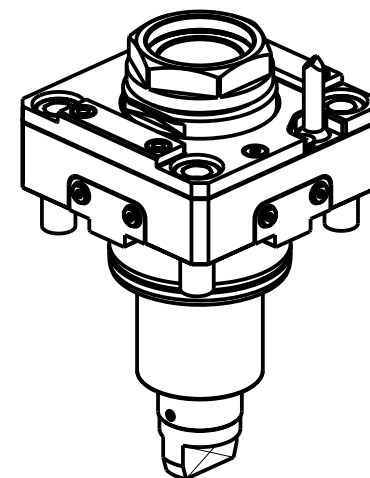

PER PORTAUTENSILI MODULARI MTSK-40 VEDI PAG. TBL300-1-40 E PER MTSK-50 VEDI PAG. TBL300-1-50  
FOR MTSK-40 QUICK CHANGE TOOLHOLDERS CLAMPINGS SEE PAGE TBL300-1-40 AND FOR MTSK-50 SEE PAGE TBL300-1-50  
FUER MTSK-40 MODULARE WERKZEUGAUFNAHMEN SIEHE SEITE TBL300-1-40 UND FUER MTSK-50 SIEHE SEITE TBL300-1-50

Cod. MT	Mandrino Spindle Spindel	I	RPM	Coppia Max Max Torque Max Drehmoment	Lubrificazione int. Coolant through Innenkuehlung	Lubrificazione est. Ext. coolant Aussenkuehlung	A	CHIAVI NON INCLUSE Keys not included Schluessel nicht einbegriffen	
								CHUB	OKU
DW01550140	MTSK-40	1:1	6000	100Nm	-	X	51.5	CHUB46	OKU0650004 *
DW03480240	MTSK-40	1:1	6000	100Nm	P=70bar	X	62.5	CHUB46	OKU0650004 *
DW01550150	MTSK-50	1:1	6000	100Nm	-	X	51.5	CHUB55	OKU0650004 *
DW03480250	MTSK-50	1:1	6000	100Nm	P=70bar	X	62.5	CHUB55	OKU0650004 *

- Chiave inclusa
- Key included
- Schluessel inbegriffen

### HYUNDAI-WIA (KIA)

SKT200TTM/TTMS/TTSY - LM2000TTM/TTMS/TTSY - L2000/2100/2600/3000Y/SY - L300M/LM/MS/LMS - LV450RM/LM  
SKT250TTM/TTMS/TTSY - LM2500TTM/TTMS/TTSY - SKT250M/LM/MS - SKT300M/LM/MS - SKT-V3RM/LM - KM2600MTS - HD2600/3100 (BMT65)

MODULO MOTORIZZATO RADIALE MAGGIORATO MTSK  
Radial MTSK reinforced driven tool  
Radial MTSK angetriebenes Werkzeug vergroessert

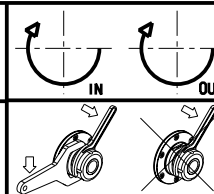

### M.T. srl

Via Casino Albini 480  
Tel. 0541/956034-957884  
Fax 0541/956341  
47842 S. GIOVANNI IN M. (RN)  
e-mail: mtma@mtmarchetti.com  
http://www.mtmarchetti.com



KIA020-3-01-K

Subject to change without notice.

09/2024