

**CUSCINETTI MAGGIORATI  
PER LAVORAZIONI PESANTI**

Reinforced bearings for heavy machining  
Vergroesserte Lager fuer schwerere Bearbeitungen

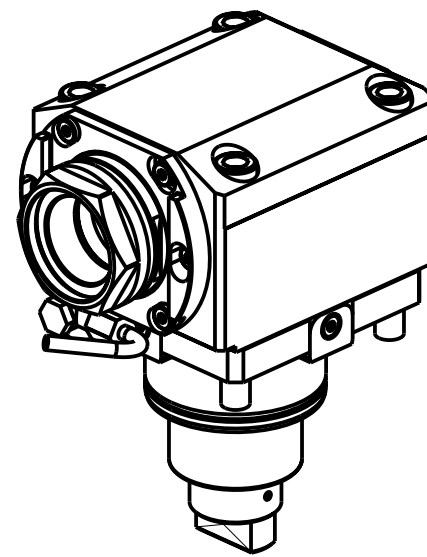

- Chiave inclusa
- Key included
- Schluessel inbegriffen

PER PORTAUTENSILI MODULARI MTSK-50 VEDI PAG. TBL300-1-50  
FOR MTSK-50 QUICK CHANGE TOOLHOLDERS CLAMPINGS SEE PAGE TBL300-1-50  
FUER MTSK-50 MODULARE WERKZEUGAUFNAHMEN SIEHE SEITE TBL300-1-50

Cod. MT	Mandrino Spindle Spindel	I	RPM	Coppia Max Max Torque Max Drehmoment	Reversibile lato mandrino/contromandrino Reversible sub/main spindle side Umkehrbare Spindel-seite/ Gegen-spindel-seite	Lubr.interna Coolant through Innenkuehlung	Lubr.esterna Ext. coolant Aussenkuehlung	B	CHIAVI NON INCLUSE Keys not included Schluessel nicht einbegriffen	
DW 02140150	MTSK-50	1:1	6000	140Nm	X	-	X	64	C HUB55	OKU0430007 ▪
DW 02140250	MTSK-50	1:1	6000	140Nm	X	P=70bar	X	76.5	C HUB55	OKU0430007 ▪

HYUNDAI-W IA (KIA)  
MOD: LV800RM/LM - SKT-V80RM/LM

MODULO MOTORIZZATO ASSIALE MAGGIORATO MTSK H=60mm  
Axial MTSK reinforced driven tool H=60mm  
Axial MTSK angetriebenes Werkzeug vergroessert H=60mm

Subject to change without notice.

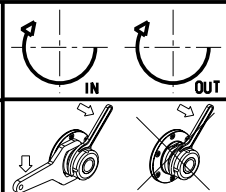

**M.T. srl**  
Via Casino Albini 480  
Tel. 0541/956034-957884  
Fax 0541/956341  
47842 S. GIOVANNI IN M. (RN)  
e-mail: mtma@mtmarchetti.com  
http://www.mtmarchetti.com



KIA170-4-10-K