

**CUSCINETTI MAGGIORATI
PER LAVORAZIONI PESANTI**

Reinforced bearings for heavy machining
Vergroesserte Lager fuer schwerere Bearbeitungen

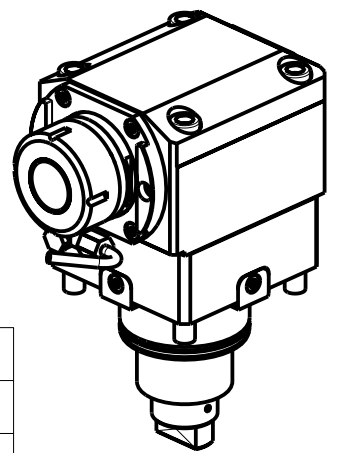

- Chiave inclusa
- Key included
- Schluessel inbegriffen

Cod. MT	Mandrino Spindle Spindel	I	RPM	Coppia Max Max Torque Max Drehmoment	Reversibile lato mandrino/contromandrino Reversible sub/main spindle side Umkehrbare Spindel-seite/ Gegenspindel-seite	Lubrificazione int. Coolant through Innenkuehlung	Lubrificazione est. Ext. coolant Aussenkuehlung	A	A1	A2	B	D	L	CHIAVI NON INCLUSE Keys not included Schluessel nicht einbegriffen	
DW 00650140	ER40	1:1	6000	140Nm	X	-	X	109.7	-	-	64	-	-	CHSTER40	OKU0430007 •
DW 00650240	ER40	1:1	6000	140Nm	X	P=70bar	X	109.7	-	-	76.5	-	-	CHSTER40	OKU0430007 •
DW 00650725	WELDON 25	1:1	6000	140Nm	X	-	X	-	109.5	-	64	-	-	-	-
DW 00650825	WELDON 25	1:1	6000	140Nm	X	P=70bar	X	-	109.5	-	76.5	-	-	-	-
DW 00650522	Ø22x19	1:1	6000	140Nm	X	-	X	-	-	89	64	22	19	CH_VTCROCE_M10 •	OKU0430007 •

HYUNDAI-W IA (KIA)

MOD: SKT400M/LMC - L400/500 MA/MC/LMC - LV500RM/LM - LV8500RM/LM - L4000M/LM/MC/LMC - L5100LM/LMC/LY

MODULO MOTORIZZATO ASSIALE MAGGIORATO H=90mm
Axial reinforced driven tool H=90mm
Axial angetriebenes Werkzeug vergroessert H=90mm

Subject to change without notice.

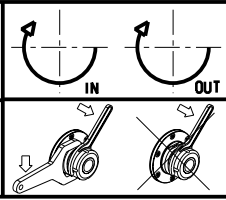

M.T. srl
Via Casino Albini 480
Tel. 0541/956034-957884
Fax 0541/956341
47842 S. GIOVANNI IN M. (RN)
e-mail: mtma@mtmarchetti.com
http://www.mtmarchetti.com



KIA170-4-20