

-LA FUNZIONE DI POLIGONATURA/DENTATURA DEVE ESSERE INSTALLATA SULLA MACCHINA
 -POLYGON CUTTING/GEAR HOBBING FUNCTION MUST BE INSTALLED ON THE MACHINE
 -DIE FUNKTION FÜR POLYGON-BZW.VERZÄHNUNGSFRÄSEN MUSS AUF DER MASCHINE FREIGESCHALTET WERDEN

ATTENZIONE - ATTENTION - ACHTUNG

- VERIFICARE LE MISURE DI INGOMBRO PER POSSIBILE INTERFERENZA SU ALCUNI MODELLI DI MACCHINE
- Please check the overall sizes for possible interferences on some machine models
- Bitte überprüfen sie das ausmass um mögliche interferenzen auf einigen maschinen modellen zu vermeiden

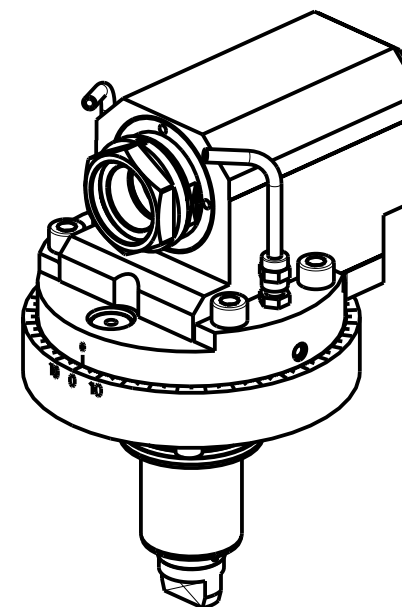

-SOLO PER MACCHINE CON ASSE Y
 -ONLY FOR MACHINES WITH Y AXIS
 -NUR FÜR MASCHINEN MIT Y-ACHSE

PER PORTAUTENSILI MODULARI MTSK-40 VEDI PAG. TBL300-1-40
 FOR MTSK-40 QUICK CHANGE TOOLHOLDERS CLAMPINGS SEE PAGE TBL300-1-40
 FÜR MTSK-40 MODULARE WERKZEUGAUFNAHMEN SIEHE SEITE TBL300-1-40

| Cod. MT | Mandrino Spindle Spindel | I | RPM | Coppia Max Max Torque Max Drehmoment | Reversibile lato mandrino/contromandrino Reversible sub/main spindle side Umkehrbare Spindel-seite/Gegenspindel-seite | Lubr.esterna Ext. coolant Aussenkuehlung | CHIAVI INCLUDE Keys included Schluessel einbegriffen |
|------------|--------------------------|-----|------|--------------------------------------|---|--|--|
| DW01770100 | MTSK-40 | 1:1 | 6000 | 50Nm | X | X | n°2 CHUB46 |

HYUNDAI-WIA (KIA)
 SKT200TTSY - LM2000TTSY - SKT250TTSY - LM2500TTSY - L2000/2600/3000Y/SY

MODULO MOTORIZZATO ASSIALE MTSK PER POWER SKIVING H=100mm
 Axial MTSK driven tool for Power Skiving H=100mm
 Axial MTSK angetriebenes Werkzeug fuer Power Skiving H=100mm

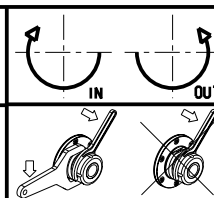

M.T. srl
 Via Casino Albini 480
 Tel. 0541/956034-957884
 Fax 0541/956341
 47842 S. GIOVANNI IN M. (RN)
 e-mail: mtma@mtmarchetti.com
 http://www.mtmarchetti.com

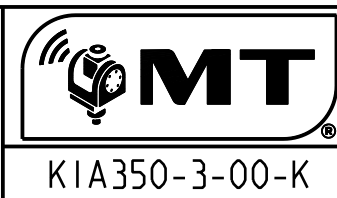

Subject to change without notice.