

-COMPATIBILE CON UTENSILI COMMERCIALI AD INSERTI  
 -COMPATIBLE WITH COMMERCIAL INSERT CUTTING-TOOLS  
 -KOMPATIBEL MIT HANDELSÜBLICHEN SCHNEIDWERKZEUGEN

**ATTENZIONE - ATTENTION - ACHTUNG**

- VERIFICARE LE MISURE DI INGOMBRO PER POSSIBILE INTERFERENZA SU ALCUNI MODELLI DI MACCHINE
- Please check the overall sizes for possible interferences on some machine models
- Bitte überprüfen sie das ausmass um mögliche interferenzen auf einigen maschinen modellen zu vermeiden

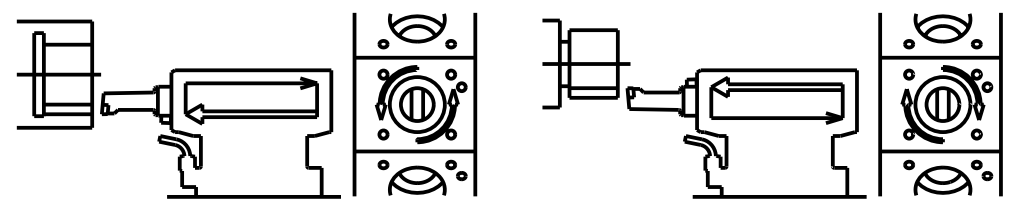
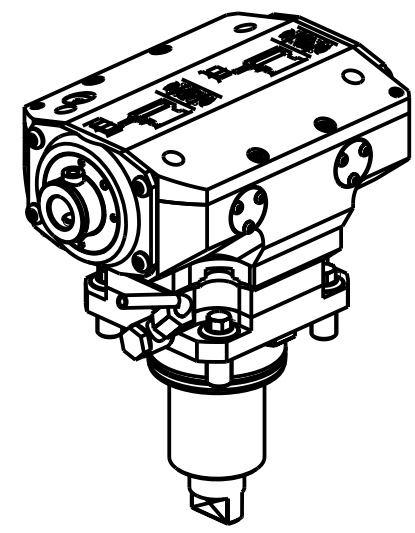
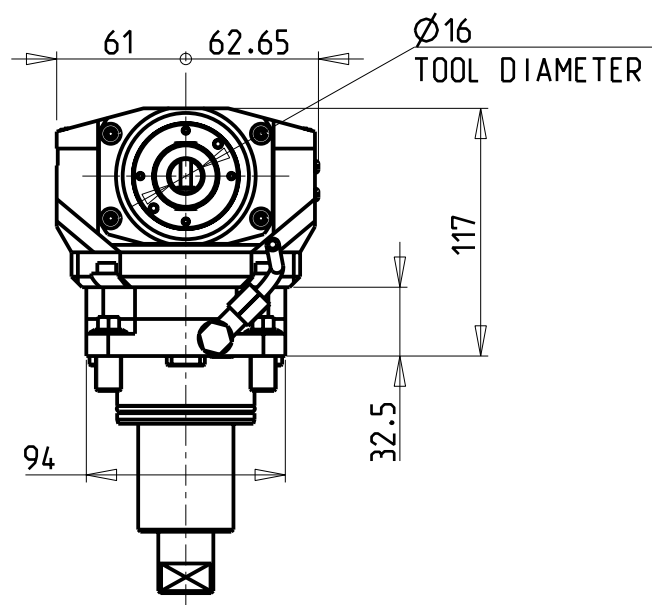
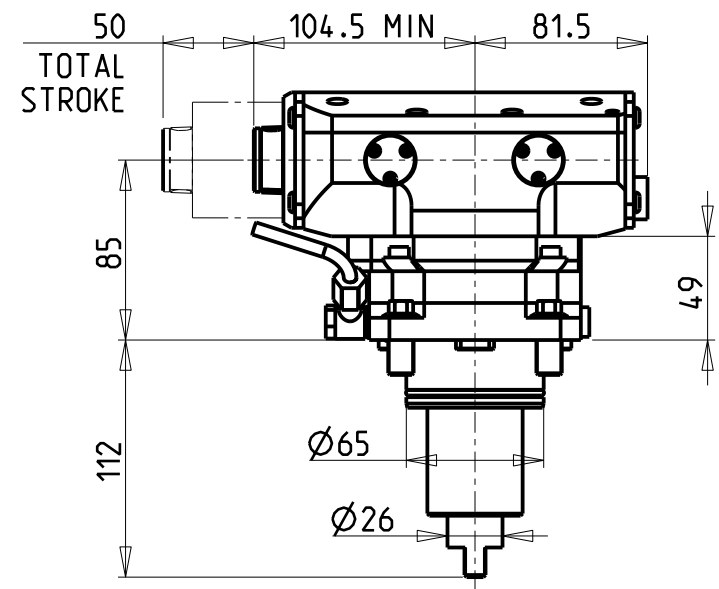
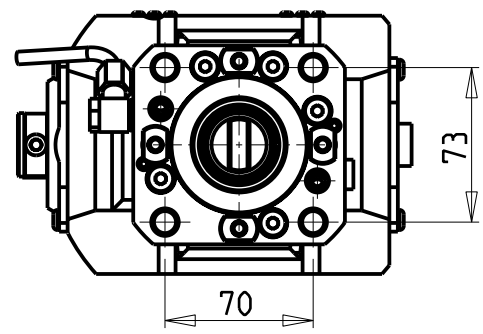

Cod. MT	I	RPM MAX	Reversibile lato mandrino/contromandrino Reversible sub/main spindle side Umkehrbare Spindelseite/ Gegenspindelseite	Lubr. esterna Ext. coolant Aussenkuehlung
DW04120100	1:1	500	X	X

HYUNDAI-WIA (KIA)

SKT200TTM/TTMS/TTSY - LM2000TTM/TTMS/TTSY - SKT250TTM/TTMS/TTSY - LM2500TTM/TTMS/TTSY  
 SKT250M/LM/MS - SKT300M/LM/MS - L300M/LM/MS/LMS - L2000/2100/2600/3000Y/SY - HD2600/3100 (BMT65)

MODULO MOTORIZZATO BROCCIAATORE CORSA 50mm H=85mm

Driven Broaching Toolholder 50mm stroke H=85mm

Angetriebenes Nutzenstoßwerkzeug 50mm Hub H=85mm

**M.T. srl**  
 Via Casino Albini 480  
 Tel. 0541/956034-957884  
 Fax 0541/956341  
 47842 S. GIOVANNI IN M. (RN)  
 e-mail: mtma@mtmarchetti.com  
 http://www.mtmarchetti.com



KIA360-3-50

Subject to change without notice.

09/2024