

**ATTENZIONE - ATTENTION - ACHTUNG**

- Per lo smontaggio degli utensili utilizzare sempre la chiave di contrasto come indicato nel manuale d'uso.
- For disassembly of the tools use always the contrast key as mentioned in the user instructions.
- Fuer das Abmontieren der Werkzeuge immer den Gegenschlüssel benutzen wie in der Bedienungsanleitung erwaehnt.

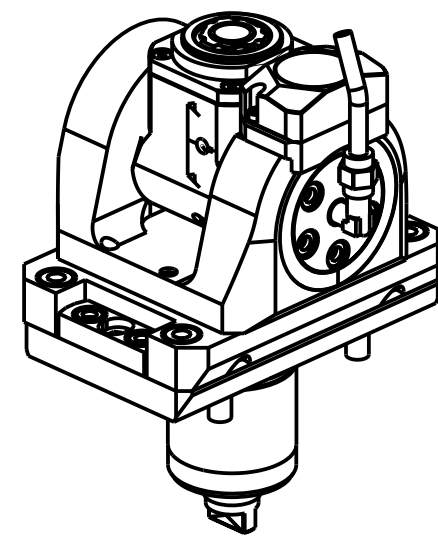
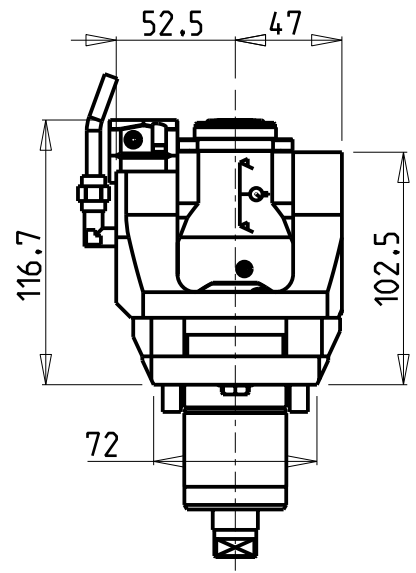
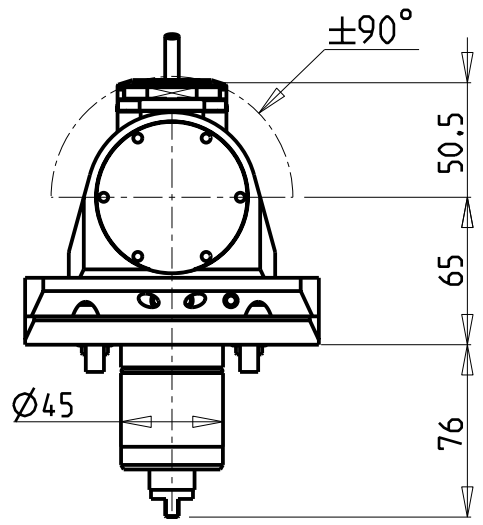
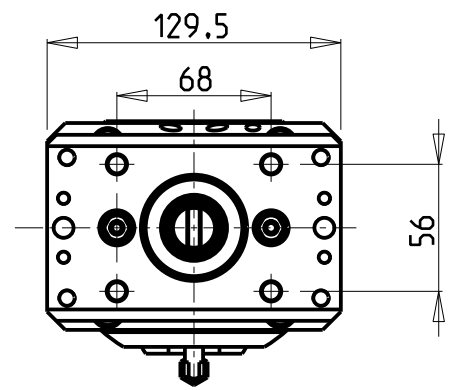

Cod. MT	Mandrino Spindle Spindel	I	RPM	Coppia Max Max Torque Max Drehmoment	Reversibile lato mandrino/contromandrino Reversible sub/main spindle side Umkehrbare Spindel-seite/ Gegenspindel-seite	Lubrificazione int. Coolant through Innenkuehlung	Lubrificazione est. Ext. coolant Aussenkuehlung	CHIAVI INCLUSE Keys included Schluessel inbegriffen			
					X	-	X	CHUB36	CHUB22	CHESL06	CHTAER20ZC
MYA0085120	ERA20	1:1	6000	30Nm	X	-	X	CHUB36	CHUB22	CHESL06	CHTAER20ZC
MYA0085220	ERA20	1:1	6000	30Nm	X	P=70bar	X	CHUB36	CHUB22	CHESL06	CHTAER20ZC

**MIYANO**

MOD: ABX-51/64 SY/TH2/TH3 - BND-51 C/S/SY - BNE-34/51 S/SY/MSY - BNJ-34/42/51 S/SY - BNX-42/51 SY

MODULO MOTORIZZATO ORIENTABILE ±90° CON NONIO DIGITALE

±90° adjustable angle driven tool with digital display

Angetriebenes Werkzeug schwenkbar ±90° mit digital display

Subject to change without notice.

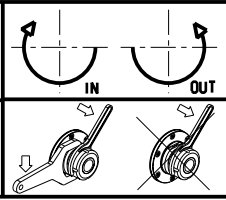

**M.T. srl**

Via Casino Albini 480  
Tel. 0541/956034-957884  
Fax 0541/956341  
47842 S. GIOVANNI IN M. (RN)  
e-mail: mtma@mtmarchetti.com  
http://www.mtmarchetti.com



MYA335-2-01