

ATTENZIONE - ATTENTION - ACHTUNG

- VERIFICARE LE MISURE DI INGOMBRO PER POSSIBILE INTERFERENZA SU ALCUNI MODELLI DI MACCHINE
- Please check the overall sizes for possible interferences on some machine models
- Bitte überprüfen sie das ausmass um mögliche interferenzen auf einigen maschinen modellen zu vermeiden

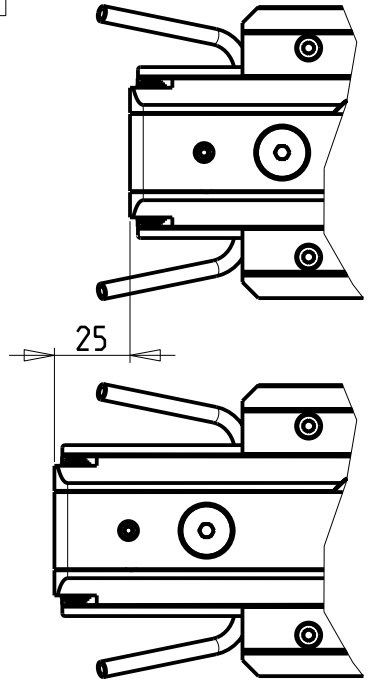
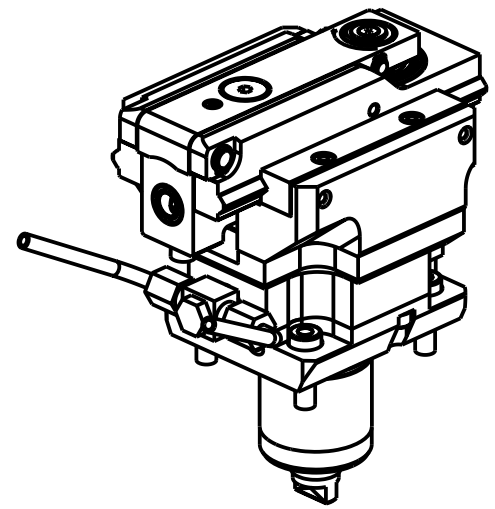

DOTAZIONI - SUPPLIED WITH - AUSSTATTUNG

- N°1 Boccola di riduz. Ø16-Ø12 e N°1 Boccola di riduz. Ø16-Ø10
- N°1 Reduction bush Ø16-Ø12 and N°1 Reduction bush Ø16-Ø10
- N°1 Reduzierbuchsen Ø16-Ø12 und N°1 Reduzierbuchsen Ø16-Ø10

PER UTENSILI STOZZATORI VEDI PAG. TBL400-1-00
 FOR DRIVEN SLOTTING TOOL CUTTING-TOOLS SEE PAGE TBL400-1-00
 FÜR NUTENSTOSS-WERKZEUG SCHNEIDWERKZEUGE SIEHE SEITE TBL400-1-00

Cod. MT	I	RPM MAX	Reversibile lato mandrino/contromandrino Reversible sub/main spindle side Umkehrbare Spindel-seite/ Gegenspindel-seite	Lubr. esterna Ext. coolant Aussenkuehlung
MYA0050200	4:1	2400	X	X

MIYANO

MOD: ABX-51/64 SY/TH2/TH3 - BND-51 C/S/SY - BNE-34/51 S/SY/MSY - BNJ-34/42/51 S/SY - BNX-42/51 SY

MODULO MOTORIZZATO STOZZATORE CORSA 25mm H=85mm
 Slotting driven tool 25mm stroke H=85mm
 Keilnutenstossmaschine 25mm Hub H=85mm

M.T. srl
 Via Casino Albini 480
 Tel. 0541/956034-957884
 Fax 0541/956341
 47842 S. GIOVANNI IN M. (RN)
 e-mail: mtma@mtmarchetti.com
 http://www.mtmarchetti.com



MYA360-2-01

Subject to change without notice.