

**ATTENZIONE - ATTENTION - ACHTUNG**

- VERIFICARE LE MISURE DI INGOMBRO PER POSSIBILE INTERFERENZA SU ALCUNI MODELLI DI MACCHINE
- Please check the overall sizes for possible interferences on some machine models
- Bitte überprüfen sie das ausmass um mögliche interferenzen auf einigen maschinen modellen zu vermeiden

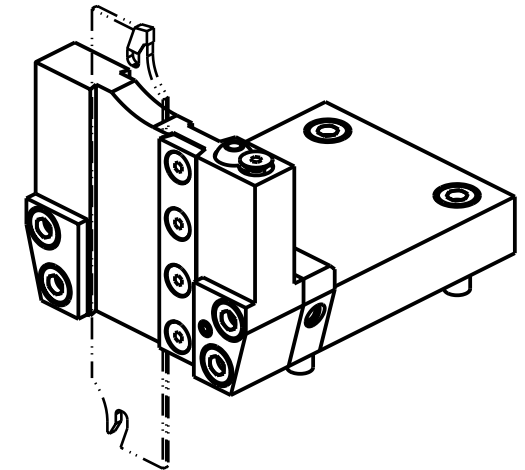
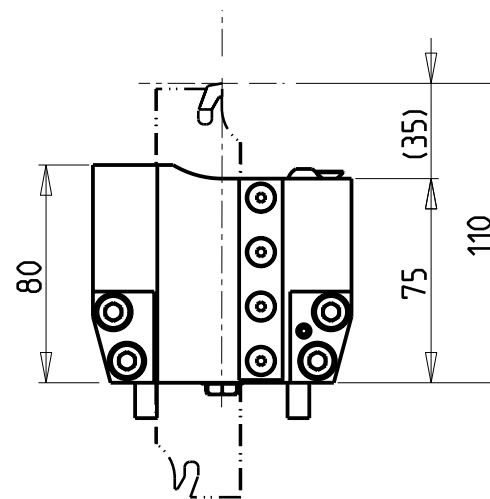
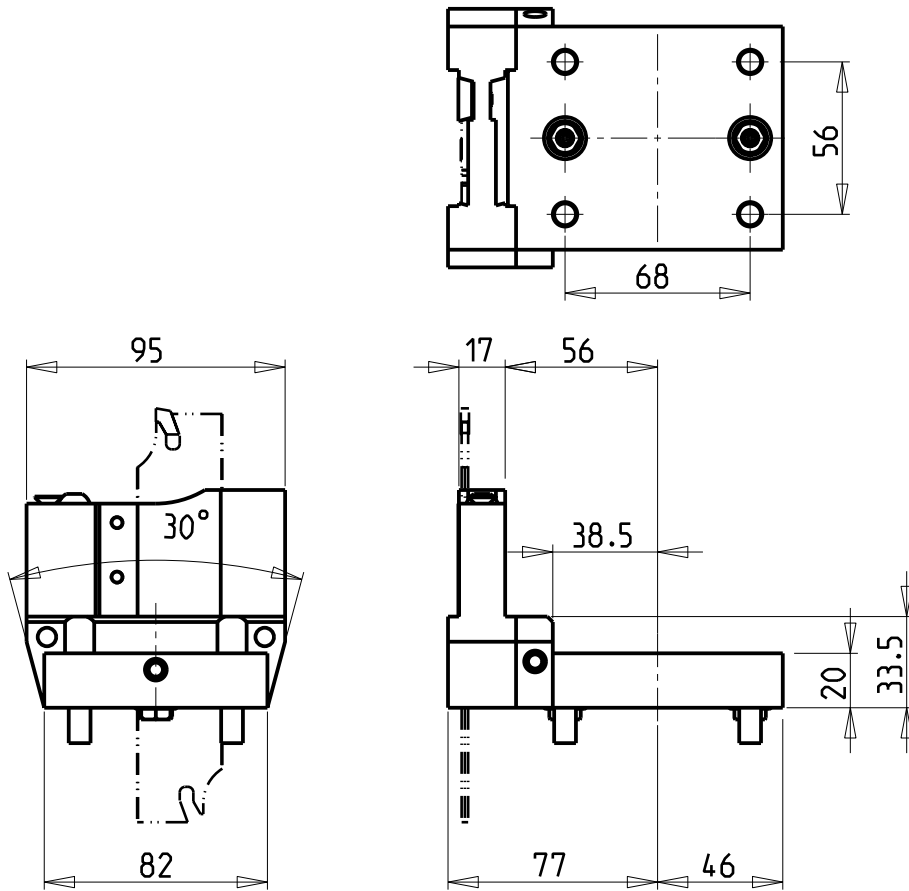

**DOTAZIONI - SUPPLIED WITH - AUSSTATTUNG**

- N°1 - LAMA - BLADE - KLINGE ISCAR H=32 Sp. 3/4mm (KENNAMETAL OPTIONAL)
- N°10 - INSERTI - INSERTS - EINLAGEN
- N°1 - CHIAVE A T PER MONTAGGIO INSERTI  
- T-WRENCH FOR INSERT SET UP  
- T-SCHLUESSEL FUER EINSATZSTUECK-MONTAGE

POSSIBILITA' DI LAVORO M3/M4  
OPTION OF M3/M4 WORKING  
ARBEITSMÖGLICHKEIT M3/M4

Cod. MT	N°Utensili N° Tools N° Werkzeuge	Lubr.esterna Ext. coolant Aussenkuehlung
MYA0260132	1	X

MIYANO

MOD: ABX-51/64 SY/TH2/TH3 - BND-51 C/S/SY - BNE-34/51 S/SY/MSY - BNJ-34/42/51 S/SY - BNX-42/51 SY

PORTAUTENSILE PER LAMA DOPPIO

Radial double blade holder  
Radial Doppel-Abstechhalter

Subject to change without notice.

**M.T. srl**

Via Casino Albini 480  
Tel. 0541/956034-957884  
Fax 0541/956341  
47842 S. GIOVANNI IN M. (RN)  
e-mail: mtma@mtmarchetti.com  
http://www.mtmarchetti.com



MYA520-2-00