

ATTENZIONE - ATTENTION - ACHTUNG

- Per lo smontaggio degli utensili utilizzare sempre la chiave di contrasto come indicato nel manuale d'uso.
- For disassembly of the tools use always the contrast key as mentioned in the user instructions.
- Fuer das Abmontieren der Werkzeuge immer den Gegenschlüssel benutzen wie in der Bedienungsanleitung erwäehnt.

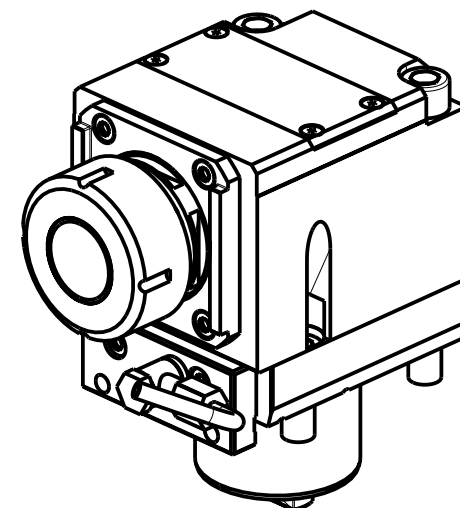

Cod. MT	Mandrino Spindle Spindel	I	RPM	Coppia Max Max Torque Max Drehmoment	Reversibile lato mandrino/contromandrino Reversible sub/main spindle side Umkehrbare Spindel-seite/ Gegenspindel-seite	Lubrificazione int. Coolant through Innenkuehlung	Lubrificazione est. Ext. coolant Aussenkuehlung	A	B	CHIAVI NON INCLUSE Keys not included Schlüssel nicht einbegriffen	
OKU0320132	ER32	2:1	3000	90Nm	X	-	X	98.7	53	CHSTER32	OKU0650004
OKU0320232	ER32	2:1	3000	90Nm	X	P=70bar	X	98.7	64	CHSTER32	OKU0650004
OKU0320140	ER40	2:1	3000	90Nm	X	-	X	101.7	53	CHSTER40	OKU0650004
OKU0320240	ER40	2:1	3000	90Nm	X	P=70bar	X	101.7	64	CHSTER40	OKU0650004

• Chiave inclusa
• Key included
• Schlüssel inbegriffen

OKUMA
 MOD: LB2000-2500-3000EX(I) M/MY/MW/MYW - LB2000-2500-3000EX(II) M/MY/MW/MYW - LU3000EX M/MY/MW
 GENOS L300MW/MYW - GENOS L3000e M/MY

MODULO MOTORIZZATO ASSIALE RIDOTTO I=2:1
 Axial geared-down I=2:1 driven tool
 Axial angetriebenes Werkzeug untersetzt I=2:1

Subject to change without notice.

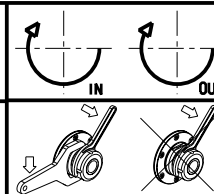

M.T. srl
 Via Casino Albini 480
 Tel. 0541/956034-957884
 Fax 0541/956341
 47842 S. GIOVANNI IN M. (RN)
 e-mail: mtma@mtmarchetti.com
 http://www.mtmarchetti.com



OKU190-4-10