

ATTENZIONE - ATTENTION - ACHTUNG

- Per lo smontaggio degli utensili utilizzare sempre la chiave di contrasto come indicato nel manuale d'uso.
- For disassembly of the tools use always the contrast key as mentioned in the user instructions.
- Fuer das Abmontieren der Werkzeuge immer den Gegenschlüssel benutzen wie in der Bedienungsanleitung erwaeht.

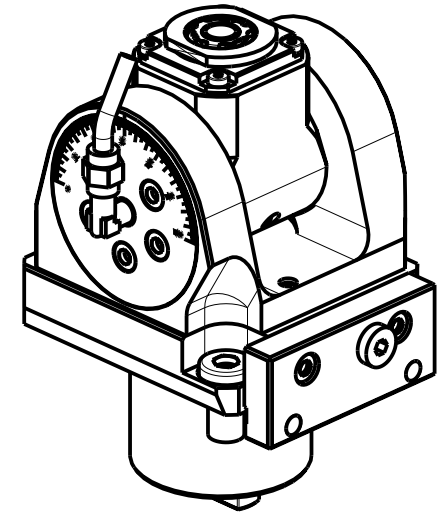
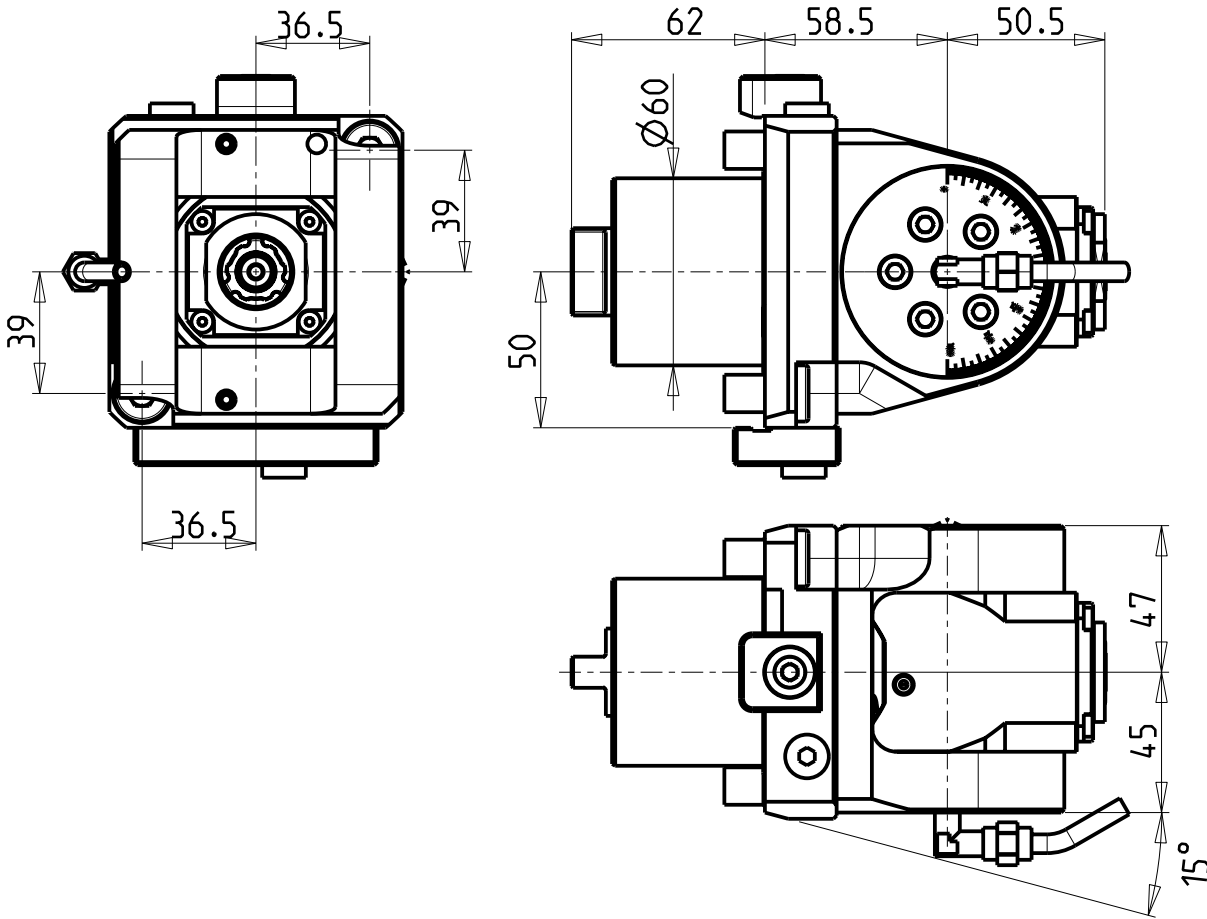

| Cod. MT | Mandrino Spindle Spindel | I | RPM | Coppia Max Max Torque Max Drehmoment | Lubrificazione int. Coolant through Innenkuehlung | Lubrificazione est. Ext. coolant Aussenkuehlung | CHIAVI INCLUSE Keys included Schluessel inbegriffen | | | |
|------------|--------------------------|-----|-------|--------------------------------------|---|---|---|---------|-------------|----------|
| | | | | | | | C HUB19_SP3 | C HUB32 | C HTAER16ZC | C HESL08 |
| OKU0080316 | ERA16 | 1:2 | 12000 | 8Nm | | X | C HUB19_SP3 | C HUB32 | C HTAER16ZC | C HESL08 |
| OKU0080416 | ERA16 | 1:2 | 12000 | 8Nm | P=70bar | X | C HUB19_SP3 | C HUB32 | C HTAER16ZC | C HESL08 |

OKUMA
 MOD: LB2000-2500-3000EX(I) M/MY/MW/MYW - LB2000-2500-3000EX(II) M/MY/MW/MYW - LU3000EX M/MY/MW
 MULTUS U3000/4000/5000 2SW - GENOS L300MW/MYW - GENOS L3000e M/MY

MODULO MOTORIZZATO ORIENTABILE +/-90° MOLTIPLICATO I=1:2
 +/-90° adjustable angle driven tool Geared-up I=1:2
 Angetriebenes Werkzeug schwenkbar +/-90° uebersetzt I=1:2

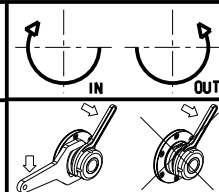

M.T. srl
 Via Casino Albini 480
 Tel. 0541/956034-957884
 Fax 0541/956341
 47842 S. GIOVANNI IN M. (RN)
 e-mail: mtma@mtmarchetti.com
 http://www.mtmarchetti.com



OKU336-4-00

Subject to change without notice.