

-LA FUNZIONE DI POLIGONATURA/DENTATURA DEVE ESSERE INSTALLATA SULLA MACCHINA
 -POLYGON CUTTING/GEAR HOBBING FUNCTION MUST BE INSTALLED ON THE MACHINE
 -DIE FUNKTION FÜR POLYGON-BZW .VERZÄHNUNGSFRÄSEN MUSS AUF DER MASCHINE FREIGESCHALTET WERDEN

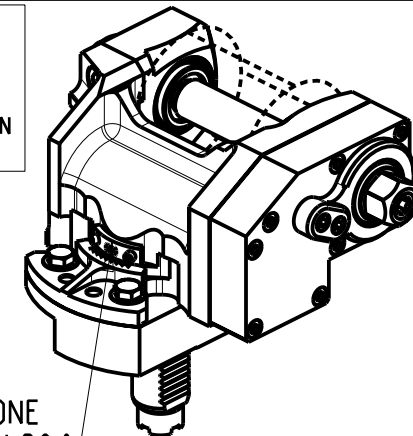

INCLINAZIONE REGOLABILE $\pm 20^\circ$

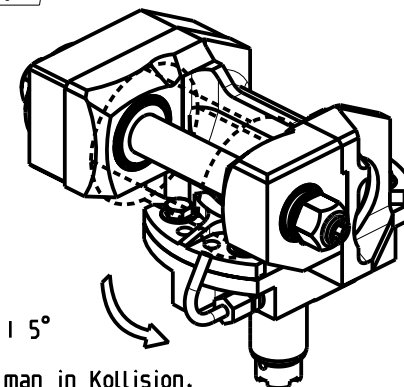

VERSO NEL QUALE OLTRE I 5° SI VA' IN COLLISIONE
 Gerichtet ueber 5° geht man in Kollision.
 Directed over 5° it will have a collision.

TORRETTE RADIALI
 RADIAL TURRETS
 RADIAL REVOLVER

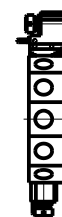

DOTAZIONI - SUPPLIED WITH - AUSSTATTUNG

- mm / inch
- N°1 ALBERO + DISTANZIALI
 - N°1 SHAFT + SPACER
 - N°1 DORN + ABSTANDSSTUECK

PER ALBERI E DISTANZIALI VEDI PAG. TBL250-1-00
 FOR SHAFT END SPACER SEE PAGE TBL250-1-00
 FUER DORN UND ABSTANDSSTUECK SEITE TBL250-1-00

Cod. MT	I	RPM max	Coppia Max Max Torque Max Drehmoment	Lubrificazione est. Ext. coolant Aussenkuehlung	B	D (mm)	D (Inch)	CHIAVI INCLUSE Keys included Schluessel inbegriffen		
								CHUB13	CHUB24	CHESL08
OKU0031100	1:1	4000	60Nm	X	93	16-22-27-32	3/4"-1"-1 1/4"	CHUB13	CHUB24	CHESL08
OKU0032100	2:1	2000	80Nm	X	101	16-22-27-32	3/4"-1"-1 1/4"	CHUB13	CHUB24	CHESL08

OKUMA
 MOD: LT200 - LT10M

MODULO MOTORIZZATO PORTACREATORE VD130

Driven gear hobber VD130

Angetriebenes Zahnradwaeltzraes-Werkzeug VD130

Subject to change without notice.

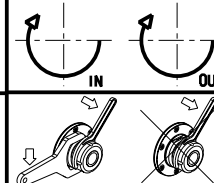

M.T. srl

Via Casino Albini 480
 Tel. 0541/956034-957884
 Fax 0541/956341
 47842 S. GIOVANNI IN M. (RN)
 e-mail: mtma@mtmarchetti.com
 http://www.mtmarchetti.com



OKU340-1-00