

INCLINAZIONE  
REGOLABILE ±20°

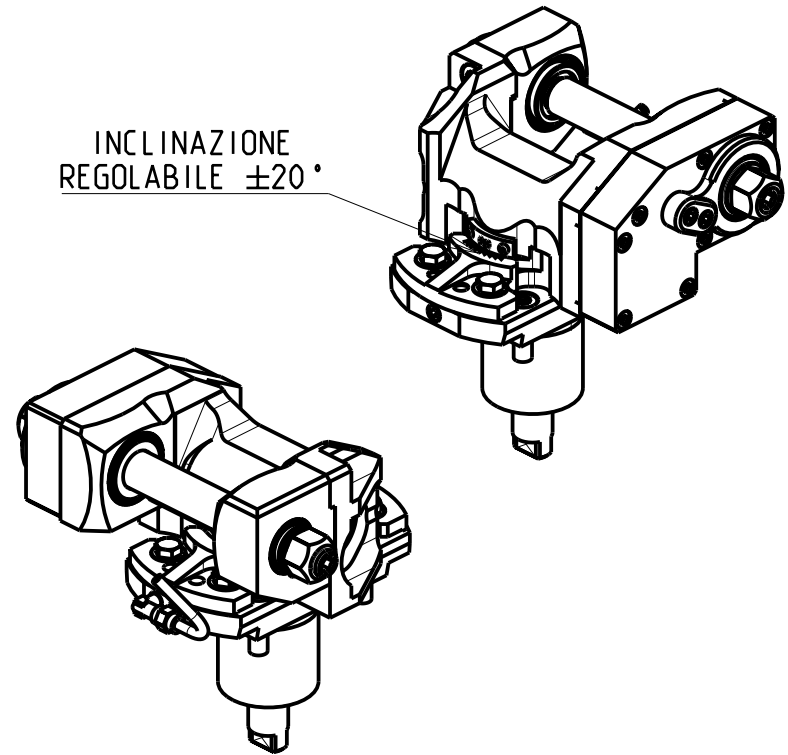

**DOTAZIONI - SUPPLIED WITH - AUSSTATTUNG**

- mm / inch
- N°1 ALBERO + DISTANZIALI
  - N°1 SHAFT + SPACER
  - N°1 DORN + ABSTANDSSTUECK

PER ALBERI E DISTANZIALI VEDI PAG. TBL250-1-00  
FOR SHAFT END SPACER SEE PAGE TBL250-1-00  
FUER DORN UND ABSTANDSSTUECK SEITE TBL250-1-00

-LA FUNZIONE DI POLIGONATURA/DENTATURA  
DEVE ESSERE INSTALLATA SULLA MACCHINA  
-POLYGON CUTTING/GEAR HOBBING FUNCTION  
MUST BE INSTALLED ON THE MACHINE  
-DIE FUNKTION FÜR POLYGON-BZW. VERZÄHNUNGSFRÄSEN  
MUSS AUF DER MASCHINE FREIGESCHALTET WERDEN

Cod. MT	I	RPM MAX	Coppia Max Max Torque Max Drehmoment	Reversibile lato mandrino/contromandrino Reversible sub/main spindle side	Lubr. esterna Ext. coolant Aussenkuehlung	D (mm)	D (Inch)	CHIAVI INCLUSE Keys included Schlüssel inbegriffen		
				Umkehrbare Spindel-seite/ Gegenspindel-seite				C HUB13	C HUB24	C HESL08
OKU0761100	1:1	6000	60Nm	X	X	16-22-27-32	3/4"-1"-1 1/4"	C HUB13	C HUB24	C HESL08
OKU0762100	2:1	3000	80Nm	X	X	16-22-27-32	3/4"-1"-1 1/4"	C HUB13	C HUB24	C HESL08

OKUMA  
MOD: LT2000EX 16ST.

MODULO MOTORIZZATO PORTACREATORE  
Driven gear hobber

Angetriebenes Zahnradwaeltzraes-Werkzeug

Subject to change without notice.

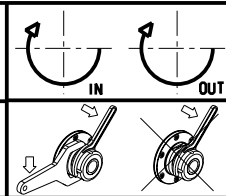

**M.T. srl**

Via Casino Albini 480  
Tel. 0541/956034-957884  
Fax 0541/956341  
47842 S. GIOVANNI IN M. (RN)  
e-mail: mtma@mtmarchetti.com  
http://www.mtmarchetti.com



OKU340-6-00