

-LA FUNZIONE DI POLIGONATURA/DENTATURA
 DEVE ESSERE INSTALLATA SULLA MACCHINA
 -POLYGON CUTTING/GEAR HOBBING FUNCTION
 MUST BE INSTALLED ON THE MACHINE
 -DIE FUNKTION FÜR POLYGON-BZW. VERZÄHNUNGSFRÄSEN
 MUSS AUF DER MASCHINE FREIGESCHALTET WERDEN

ATTENZIONE - ATTENTION - ACHTUNG

- VERIFICARE LE MISURE DI INGOMBRO PER POSSIBILE INTERFERENZA SU ALCUNI MODELLI DI MACCHINE
- Please check the overall sizes for possible interferences on some machine models
- Bitte überprüfen sie das ausmass um mögliche interferenzen auf einigen maschinen modellen zu vermeiden

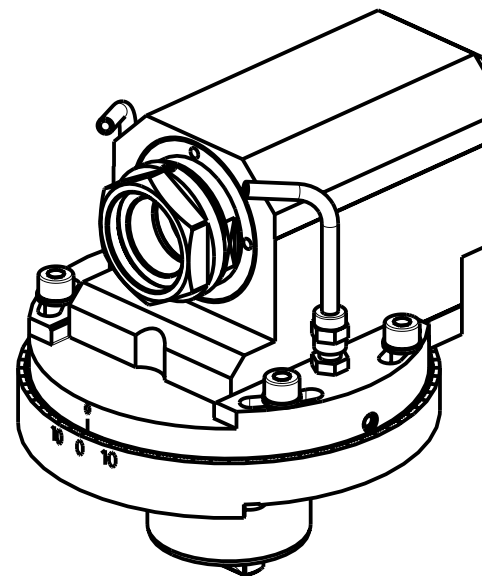
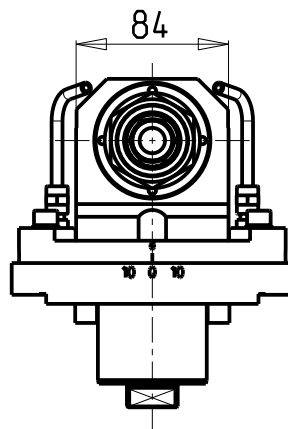

-SOLO PER MACCHINE CON ASSE Y
 -ONLY FOR MACHINES WITH Y AXIS
 -NUR FÜR MASCHINEN MIT Y-ACHSE

PER PORTAUTENSILI MODULARI MTSK-40 VEDI PAG. TBL300-1-40
 FOR MTSK-40 QUICK CHANGE TOOLHOLDERS CLAMPINGS SEE PAGE TBL300-1-40
 FÜR MTSK-40 MODULARE WERKZEUGAUFNAHMEN SIEHE SEITE TBL300-1-40

Cod. MT	Mandrino Spindle Spindel	I	RPM	Coppia Max Max Torque Max Drehmoment	Reversibile lato mandrino/contromandrino Reversible sub/main spindle side Umkehrbare Spindel-seite/ Gegenspindel-seite	Lubr.esterna Ext. coolant Aussenkuehlung	CHIAVI INCLUSE Keys included Schluessel einbegriffen
OKU1420100	MTSK-40	1:1	6000	50Nm	X	X	n°2 CHUB46

OKUMA
 MOD: LB2000-2500-3000EX(I) MY/MYW - LU2000-2500-3000EX MY - GENOS L300 MYW - GENOS L3000e MY

MODULO MOTORIZZATO ASSIALE MTSK PER POWER SKIVING H=85mm
 Axial MTSK driven tool for Power Skiving H=85mm
 Axial MTSK angetriebenes Werkzeug fuer Power Skiving H=85mm

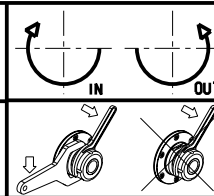

M.T. srl
 Via Casino Albini 480
 Tel. 0541/956034-957884
 Fax 0541/956341
 47842 S. GIOVANNI IN M. (RN)
 e-mail: mtma@mtmarchetti.com
 http://www.mtmarchetti.com



OKU350-4-00-K

Subject to change without notice.

09/2024