

73

Ø16
TOOL DIAMETER

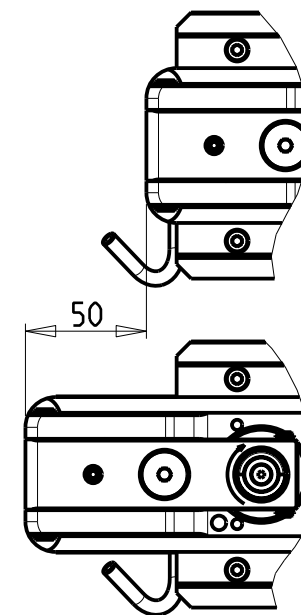
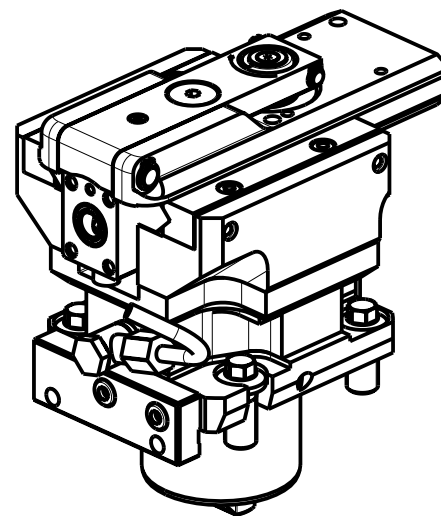
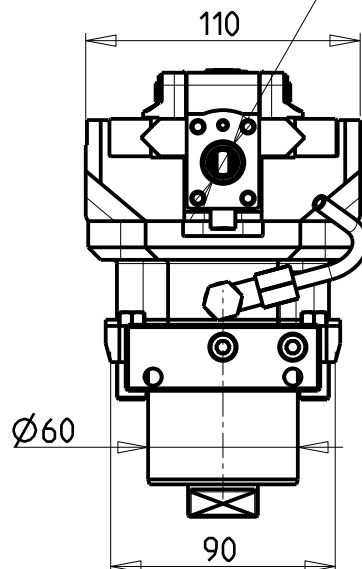
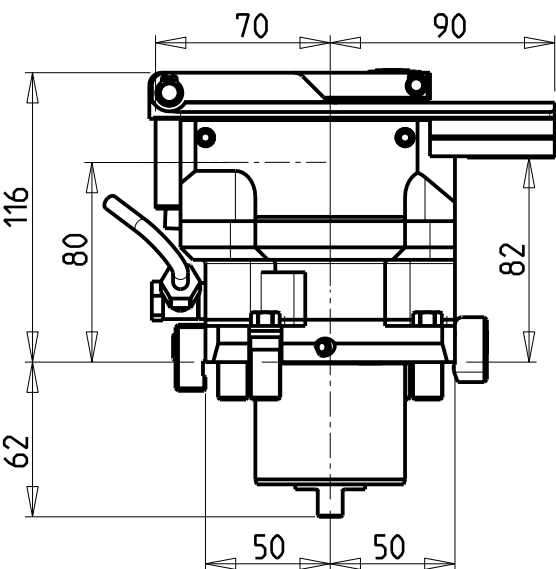

ATTENZIONE - ATTENTION - ACHTUNG

- VERIFICARE LE MISURE DI INGOMBRO PER POSSIBILE INTERFERENZA SU ALCUNI MODELLI DI MACCHINE
- Please check the overall sizes for possible interferences on some machine models
- Bitte überprüfen sie das ausmass um mögliche interferenzen auf einigen maschinen modellen zu vermeiden

DOTAZIONI - SUPPLIED WITH - AUSSTATTUNG

N°1 Boccola di riduz. Ø16-Ø12 e N°1 Boccola di riduz. Ø16-Ø10
 N°1 Reduction bush Ø16-Ø12 and N°1 Reduction bush Ø16-Ø10
 N°1 Reduzierbuchsen Ø16-Ø12 und N°1 Reduzierbuchsen Ø16-Ø10

PER UTENSILI STOZZATORI VEDI PAG. TBL400-1-00
 FOR DRIVEN SLOTTING TOOL CUTTING-TOOLS SEE PAGE TBL400-1-00
 FÜR NUTENSTOSS-WERKZEUG SCHNEIDWERKZEUGE SIEHE SEITE TBL400-1-00

Cod. MT	I	RPM MAX	Reversibile lato mandrino/contromandrino Reversible sub/main spindle side Umkehrbare Spindelseite/ Gegenspindelseite	Lubr. esterna Ext. coolant Aussenkuehlung
OKU1160100	4:1	2000	X	X

OKUMA
 MOD: LB2000-2500-3000EX(I) M/MY/MW/MYW - LB2000-2500-3000EX(II) M/MY/MW/MYW - LU3000EX M/MY/MW
 GENOS L300MW/MYW - GENOS L3000e M/MY

MODULO MOTORIZZATO STOZZATORE CORSA 50mm H=80mm
 Slotting driven tool 50mm stroke H=80mm
 Keilnutenstossmaschine 50mm Hub H=80mm

M.T. srl
 Via Casino Albini 480
 Tel. 0541/956034-957884
 Fax 0541/956341
 47842 S. GIOVANNI IN M. (RN)
 e-mail: mtma@mtmarchetti.com
 http://www.mtmarchetti.com



OKU360-4-00

Subject to change without notice.

09/2024